

# TLE5011

GMR Based Angular Sensor



Sensors



Never stop thinking

**Edition 2008-01**

**Published by Infineon Technologies AG,  
81726 München, Germany**

**© 2008 Infineon Technologies AG  
All Rights Reserved.**

#### **Legal Disclaimer**

The information given in this document shall in no event be regarded as a guarantee of conditions or characteristics. With respect to any examples or hints given herein, any typical values stated herein and/or any information regarding the application of the device, Infineon Technologies hereby disclaims any and all warranties and liabilities of any kind, including without limitation warranties of non-infringement of intellectual property rights of any third party.

#### **Information**

For further information on technology, delivery terms and conditions and prices please contact your nearest Infineon Technologies Office ([www.infineon.com](http://www.infineon.com)).

#### **Warnings**

Due to technical requirements components may contain dangerous substances. For information on the types in question please contact your nearest Infineon Technologies Office.

Infineon Technologies Components may only be used in life-support devices or systems with the express written approval of Infineon Technologies, if a failure of such components can reasonably be expected to cause the failure of that life-support device or system, or to affect the safety or effectiveness of that device or system. Life support devices or systems are intended to be implanted in the human body, or to support and/or maintain and sustain and/or protect human life. If they fail, it is reasonable to assume that the health of the user or other persons may be endangered.

# TLE5011

**Revision History:**            **2008-01**

V 0.11

Previous Version:            V 0.1

| Page    | Subjects (major changes since last revision) |
|---------|--|
| General | Spelling and typing errors corrected         |
| 51      | Package Parameters changed                   |
| 52      | Package Outline Figure modified              |
| 53      | Marking changed                              |
|         |  |
|         |  |
|         |  |
|         |  |
|         |  |
|         |  |

## **We Listen to Your Comments**

Any information within this document that you feel is wrong, unclear or missing at all?  
Your feedback will help us to continuously improve the quality of this document.

Please send your proposal (including a reference to this document) to:

[sensors@infineon.com](mailto:sensors@infineon.com)



|          |  |           |
|----------|--|-----------|
| <b>1</b> | <b>Overview</b> .....                              | <b>6</b>  |
| 1.1      | Features .....                                     | 6         |
| 1.2      | Target Applications .....                          | 7         |
| 1.3      | Product Description .....                          | 7         |
| 1.4      | Pin Configuration (top view) .....                 | 8         |
| <b>2</b> | <b>General</b> .....                               | <b>9</b>  |
| 2.1      | Functional Description .....                       | 9         |
| 2.2      | Block Diagram .....                                | 9         |
| 2.3      | Internal Power Supply .....                        | 10        |
|          | GMR Voltage Regulator VRG (VDDG-Voltage) .....     | 10        |
|          | Analog Voltage Regulator VRA (VDDA-Voltage) .....  | 10        |
|          | Digital Voltage Regulator VRD (VDDD-Voltage) ..... | 10        |
| 2.4      | GMR Functionality .....                            | 11        |
| <b>3</b> | <b>Absolute Maximum Ratings</b> .....              | <b>13</b> |
| <b>4</b> | <b>Operating Range</b> .....                       | <b>14</b> |
| <b>5</b> | <b>Electrical and Magnetic Parameters</b> .....    | <b>15</b> |
| 5.1      | Electrical Parameters .....                        | 15        |
| 5.2      | ESD Protection .....                               | 16        |
| 5.3      | GMR Parameters .....                               | 17        |
|          | Offset and Amplitude .....                         | 17        |
|          | Amplitude Definition .....                         | 18        |
|          | Offset Definition .....                            | 18        |
|          | Temperature dependent behavior .....               | 18        |
|          | Orthogonality Definition .....                     | 19        |
| 5.4      | Calibration .....                                  | 19        |
|          | GMR Values .....                                   | 19        |
|          | Temperature Measurement .....                      | 19        |
|          | Calibration Conditions .....                       | 19        |
| 5.5      | Angle Calculation .....                            | 20        |
| 5.5.1    | Components of the Output Signals .....             | 20        |
| 5.5.2    | GMR Error Compensation .....                       | 20        |
|          | Temperature dependent Offset Value .....           | 20        |
|          | Offset Correction .....                            | 21        |
|          | Amplitude Normalization .....                      | 21        |
|          | Non-Orthogonality Correction .....                 | 21        |
|          | Resulting Angle .....                              | 21        |
| 5.6      | Error Types .....                                  | 22        |
|          | Anisotropy Error .....                             | 22        |
|          | Hysteresis Error .....                             | 22        |
|          | Residual Angle Error .....                         | 22        |
| 5.7      | GMR Parameters after Calibration .....             | 23        |

|           |  |           |
|-----------|--|-----------|
| <b>6</b>  | <b>Signal Processing</b> .....                                 | <b>24</b> |
| <b>7</b>  | <b>Clock Supply (CLK Timing Definition)</b> .....              | <b>25</b> |
| <b>8</b>  | <b>Synchronous Serial Communication Interface (SSC)</b> .....  | <b>26</b> |
| 8.1       | SSC Timing Definition .....                                    | 27        |
|           | SSC Timing Diagram .....                                       | 27        |
| 8.2       | SSC Baud rate .....  | 30        |
| 8.3       | SSC Spike Filter .....   | 30        |
| 8.3.1     | SSC Spike Filter Off .....                                     | 30        |
| 8.3.2     | SSC Spike Filter On .....                                      | 31        |
|           | Filter for DATA and $\overline{CS}$ .....                      | 31        |
| 8.4       | SSC Data Transfer .....  | 32        |
| 8.5       | SSC Command Byte .....   | 32        |
| <b>9</b>  | <b>Register Table</b> .....                                    | <b>33</b> |
|           | Bit Types .....  | 34        |
|           | Reserved Registers (08 <sub>H</sub> to 0B <sub>H</sub> ) ..... | 39        |
| <b>10</b> | <b>Data Communication via SSC</b> .....                        | <b>43</b> |
| 10.1      | CRC Generation .....   | 44        |
| 10.2      | Slave Active Byte Generation .....                             | 44        |
|           | Example: Update X and Y and set ADC-Test Mode .....            | 45        |
| <b>11</b> | <b>Test Structures</b> .....                                   | <b>46</b> |
| 11.1      | Functional Angle Tests .....                                   | 46        |
|           | ADC Test Vectors .....   | 47        |
| 11.2      | Temperature Measurement .....                                  | 47        |
| 11.3      | Angle Test and Temperature Measurement Timing .....            | 48        |
| <b>12</b> | <b>Overvoltage Comparators</b> .....                           | <b>49</b> |
| 12.1      | Internal Supply Voltage Comparators .....                      | 49        |
| 12.2      | V <sub>DD</sub> Overvoltage Detection .....                    | 49        |
| 12.3      | GND - Off Comparator .....                                     | 50        |
| 12.4      | V <sub>DD</sub> - Off Comparator .....                         | 50        |
| <b>13</b> | <b>Typical Application Circuit</b> .....                       | <b>51</b> |
| 13.1      | Angle Sensor System .....                                      | 51        |
| <b>14</b> | <b>Package Information</b> .....                               | <b>52</b> |
| 14.1      | Package Parameters .....                                       | 52        |
|           | Package Outline PG-DSO-8 .....                                 | 53        |
|           | Footprint PG-DSO-8 .....                                       | 54        |
|           | Packing .....  | 54        |
|           | Marking .....  | 54        |
|           | Processing .....   | 55        |

# 1 Overview

## 1.1 Features

- **Giant Magneto Resistance (GMR)**-based principle
- Integrated magnetic field sensing for angle measurement
- Full 0 - 360° angle measurement
- Highly accurate single bit SD-ADC
- 16 bit representation of sine / cosine values on the interface
- Wide magnetic operating range: 30mT to 70mT
- Bi-directional SSC Interface up to 2 Mbit/s
- 3 pin SSC Interface, SPI compatible with open drain
- ADCs and filters are synchronized with external commands via SSC
- Test resistors for simulating angle values
- Core supply voltage 2.5 V
- 0.25 μm CMOS technology
- Automotive qualified: -40°C to +150°C (Junction Temperature)
- Latch up immunity according JEDEC standard
- ESD > 2 kV (HBM)
- Green package with lead-free (Pb-free) plating

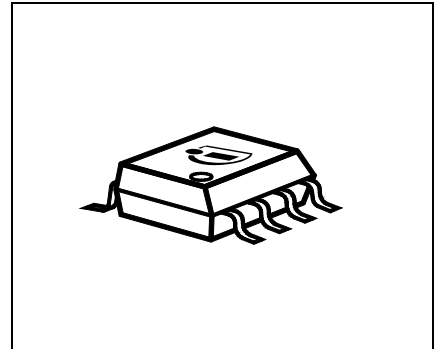

| Type    | Marking | Ordering Code | Package  |
|---------|---------|---------------|----------|
| TLE5011 | 5011    | TBD.          | PG-DSO-8 |

## 1.2 Target Applications

The TLE5011 GMR-Based Angular Sensor is designed for angular position sensing in automotive applications, such as:

- Steering Angle
- Brushless DC Motor Commutation (e.g. EPS)
- Rotary Switch
- General Angular Sensing

## 1.3 Product Description

The TLE5011 is a 360° angle sensor that detects the orientation of a magnetic field. This is achieved by measuring sine and cosine angle components with monolithic integrated Giant Magneto Resistance (GMR) elements.

Data communications are accomplished with a bi-directional SSC Interface that is SPI compatible.

The sine and cosine values can be read out. These signals can be digitally processed to calculate the angle orientation of the magnetic field (magnet). This calculation can be done by using a cordic algorithm.

It is possible to connect more than one TLE5011 to one SSC Interface of a microcontroller for redundancy or any other reasons. If multiple TLE5011 devices are used, the synchronization of the connected TLE5011 is performed by a broadcast command. Each connected TLE5011 can be addressed by a dedicated Chip Select  $\overline{CS}$  pin.

Online diagnostic functions are provided to ensure a reliable operation.

These are

- Angle test (generated via test voltages feeding the ADC).
- Crossed signal paths (switchable for comparison)
- Inverted signs of bit streams
- Over and undervoltage detections

## 1.4 Pin Configuration

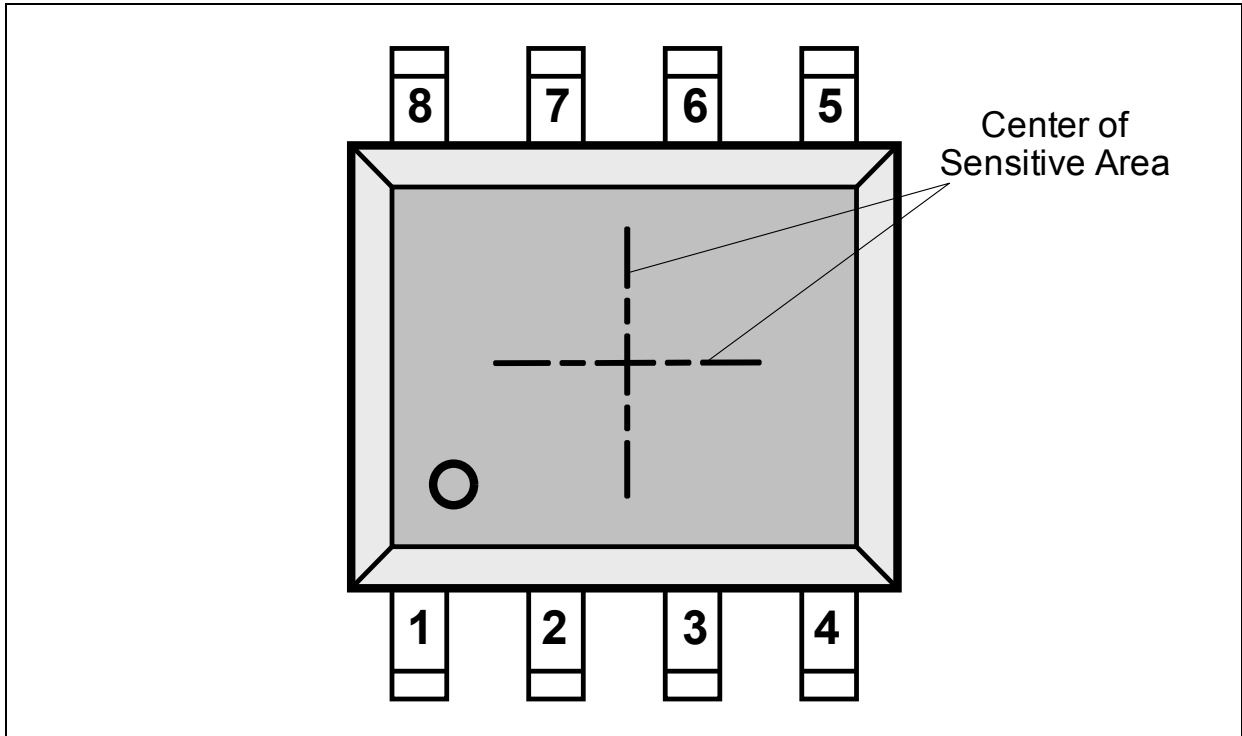

Figure 1 Pin Configuration (top view)

Table 1 Pin Definitions and Functions

| Pin No. | Symbol          | In/Out     | Function                             |
|---------|-----------------|------------|--------------------------------------|
| 1       | <i>CLK</i>      | <i>I</i>   | Chip Clock                           |
| 2       | <i>SCK</i>      | <i>I</i>   | SSC Clock                            |
| 3       | $\overline{CS}$ | <i>I</i>   | SSC Chip Select                      |
| 4       | <i>DATA</i>     | <i>I/O</i> | SSC Data, open drain                 |
| 5       | <i>TST1</i>     | <i>I/O</i> | Test Pin 1, must be connected to GND |
| 6       | $V_{DD}$        | -          | Supply Voltage                       |
| 7       | <i>GND</i>      | -          | Ground                               |
| 8       | <i>TST2</i>     | <i>I/O</i> | Test Pin 2, must be connected to GND |



## 2 General

### 2.1 Functional Description

The clock for the sensors is provided externally. This ensures a synchronously operation in case of multiple system participants.

The sensor has its own Phase Locked Loop (PLL) to generate the necessary clock frequency for the chip operation.

### 2.2 Block Diagram

The block diagram shows all switches in the reset position.

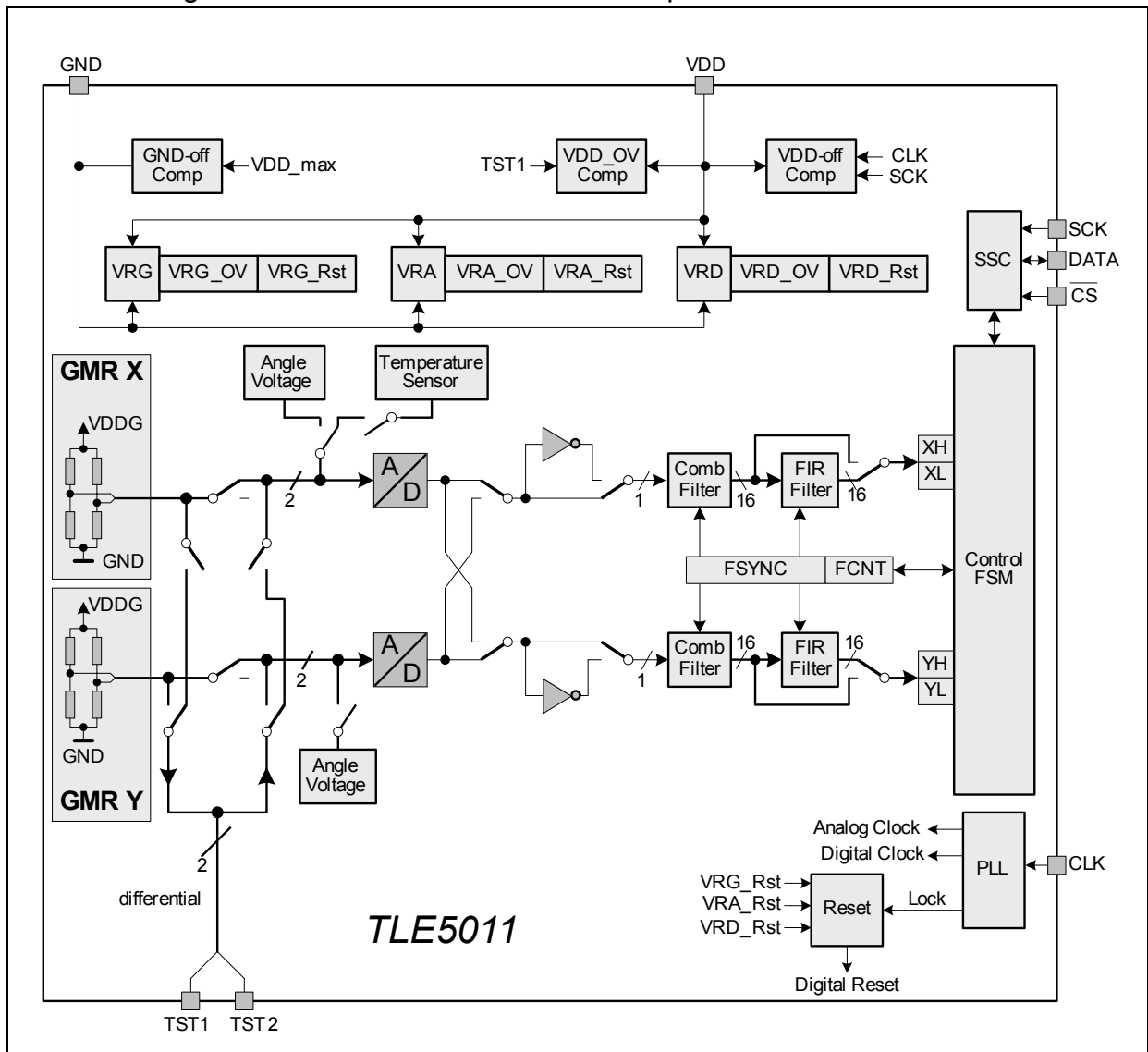

Figure 2 Block Diagram

## 2.3 Internal Power Supply

The internal stages of the TLE5011 are supplied with different voltage regulators.

- GMR Voltage Regulator VRG
- Analog Voltage Regulator VRA
- Digital Voltage Regulator VRD

Each voltage regulator has its own overvoltage and undervoltage detection circuits.

### 2.3.1 GMR Voltage Regulator VRG (VDDG-Voltage)

The GMR voltage regulator supplies all GMR parts.

- GMR Bridges
- Test Voltages for Angle Test
- ADC Reference Voltage

The voltages are monitored in the VRG overvoltage and undervoltage detectors.

### 2.3.2 Analog Voltage Regulator VRA (VDDA-Voltage)

The analog voltage regulator supplies the analog parts.

- ADCs
- PLL (analog)
- VDD-Off comparator
- GND-Off comparator
- $V_{DD}$  Overvoltage detection

The voltages are monitored in the VRA overvoltage and undervoltage detectors.

### 2.3.3 Digital Voltage Regulator VRD (VDDD-Voltage)

The digital voltage regulator supplies all digital parts.

- Comb filters, FIR filters and Low Pass filter
- PLL (digital)
- Control FSM with Bitmap
- SSC Interface
- Counters (Reset, FSYNC, FCNT)

The voltages are monitored in the VRD overvoltage and undervoltage detectors.

## 2.4 GMR Functionality

The GMR sensor is implemented in vertical integration. This means that the GMR active areas are integrated above the logic portion of the TLE5011 device. GMR elements change their resistance depending on the direction of the magnetic field.

Four individual GMR elements are connected to one Wheatstone Sensor Bridge. These GMR elements sense one of two components of the applied magnetic field:

- X component,  $V_X$  (cosine) or the
- Y component,  $V_Y$  (sine)

The advantage of a full-bridge structure is that the amplitude of the GMR signal is doubled.

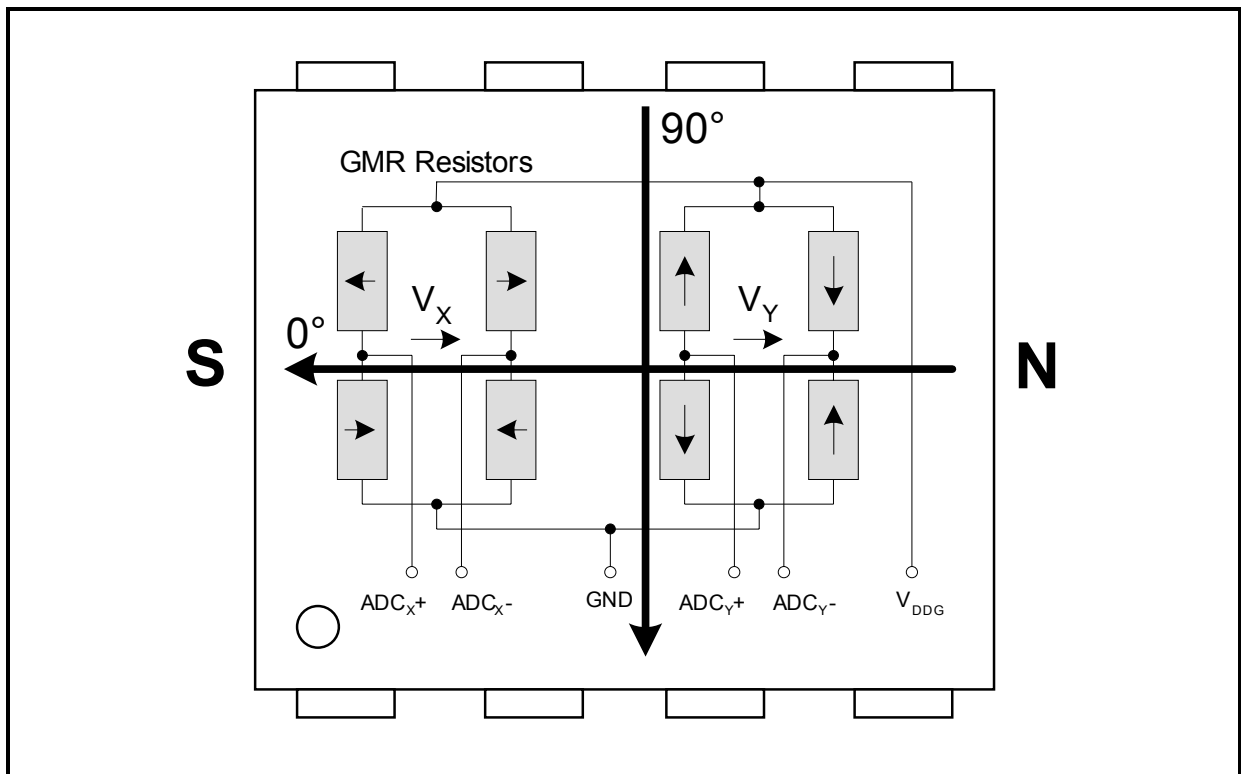

**Figure 3 Sensitive bridges of the GMR Sensor<sup>1)</sup>**

*Note: In **Figure 3**, the arrows in the resistor symbols indicate the direction of the Reference Layer.*

<sup>1)</sup> The arrows in the resistor symbols show the direction of the reference layer

**General**

The output signal of each bridge is only unambiguous over 180° between two maxima. Therefore two bridges are orientated orthogonally to each other.

Using the ARCTAN function, the true 360° angle value can be calculated that is represented by the relation of the X and Y signals.

Because only the relative values influence the result, the absolute size of the two signals is of minor importance. Therefore, most influences to the amplitudes are compensated.

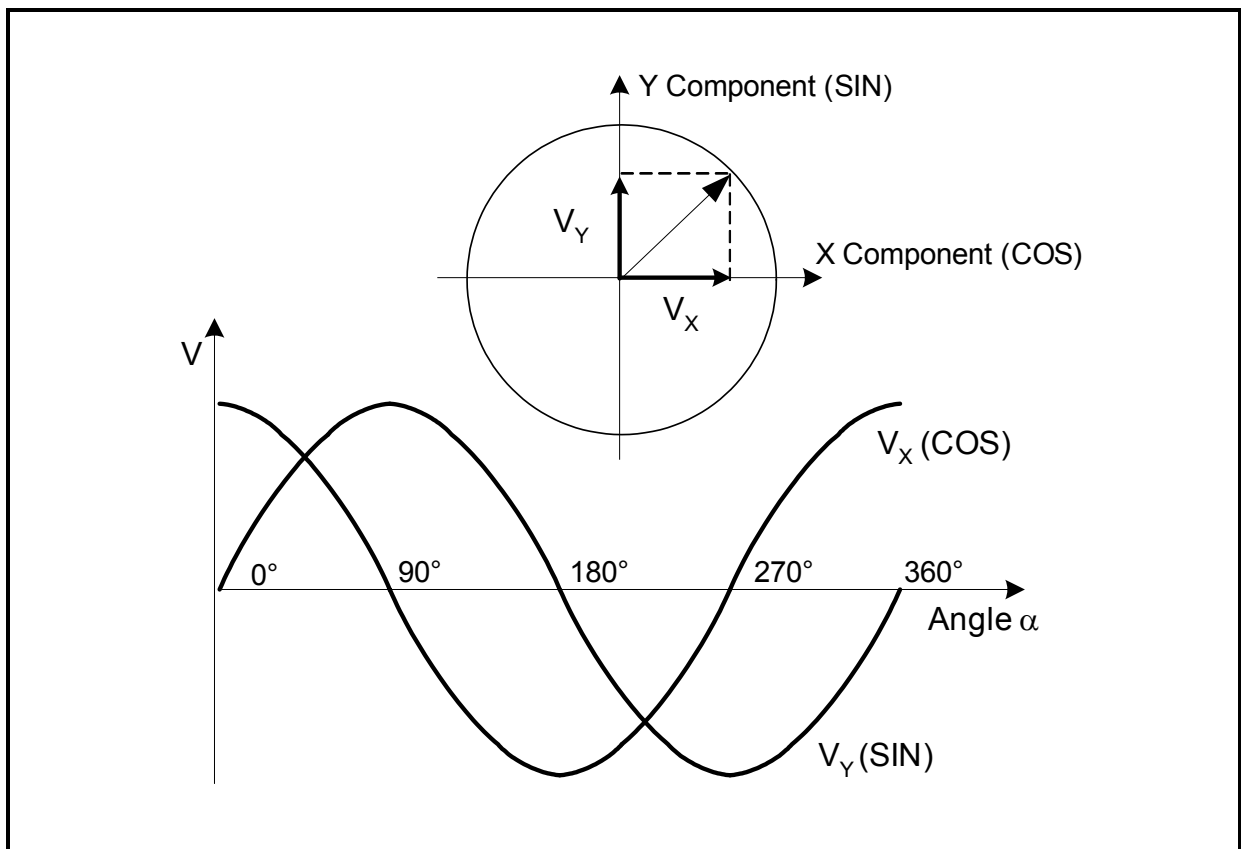

**Figure 4** Ideal Output of the GMR Sensor

**Absolute Maximum Ratings**
**3 Absolute Maximum Ratings**
**Table 2 Absolute Maximum Rating Parameters**

| Parameter  | Symbol   | Limit Values |      | Unit | Notes                                    |
|--|----------|--------------|------|------|--|
|  |          | min.         | max. |      |  |
| Voltage on $V_{DD}$ pin respect to ground ( $V_{SS}$ ) | $V_{DD}$ | -0.5         | 6.5  | V    | max 40 h / lifetime                      |
| Voltage on any pin respect to ground ( $V_{SS}$ )      | $V_{IN}$ | -0.5         | 6.5  | V    | $V_{DD} + 0.35$ V may not be exceeded    |
| Junction Temperature                                   | $T_J$    | -40          | 150  | °C   |  |
| Magnetic Field Induction                               | $B$      | -            | 125  | mT   | max 5 min. @<br>$t_A = 25^\circ\text{C}$ |
|  |          | -            | 100  |      | max 5 h @<br>$t_A = 25^\circ\text{C}$    |

*Note: Stresses above the max. value listed here may cause permanent damage to the device. Exposure to absolute maximum rating conditions for extended periods may affect device reliability. Maximum ratings are absolute ratings; exceeding only one of these values may cause irreversible damage to the integrated circuit.*

## 4 Operating Range

The operating conditions identified in [Table 3](#) must not be exceeded in order to ensure correct operation of the TLE5011. All parameters specified in the following sections refer to these operating conditions, unless otherwise noticed.

**Table 3 Operating Range**

| Parameter           | Symbol     | Limit Values |      |      | Unit  | Notes                                |
|---------------------|------------|--------------|------|------|-------|--------------------------------------|
|                     |            | min.         | typ. | max. |       |                                      |
| Supply Voltage      | $V_{DD}$   | 4.5          | -    | 5.5  | V     | 1)                                   |
| Output Current      | $I_Q$      | -            | -5   | -10  | mA    | 2) 3)                                |
| Input Voltage       | $V_{IN}$   | -0.3         | -    | 5.5  | V     | $V_{DD} + 0.5$ V may not be exceeded |
| Magnetic Induction  | $B_{XY}$   | 30           | 50   | 70   | mT    | In X / Y direction <sup>4)</sup>     |
| Angle Range         | $Ang$      | 0            | -    | 360  | °     | sine / cosine                        |
| Storage Temperature | $T_{ST}$   | -40          | -    | 50   | °C    |                                      |
| Overall Life Time   | $t_{life}$ | -            | -    | 15   | Years |                                      |

1) Directly blocked with 100 nF ceramic capacitor

2) Max current to GND over Open Drain Output

3) The corresponding voltage levels are listed in [Table 5 "Electrical Parameters" on Page 16](#)

4) Values refer to an homogenous magnetic field ( $B_{xy}$ ) without vertical magnetic induction ( $B_z = 0$  mT). By applying a vertical magnetic induction an additional error has to be considered

*Note: The thermal resistances listed in [Table 20 "Package Parameters" on Page 51](#) must be used to calculate the corresponding ambient temperature. [Table 3](#) is valid for  $-40^{\circ}\text{C} < T_J < 150^{\circ}\text{C}$ .*

## 5 Electrical and Magnetic Parameters

### 5.1 Electrical Parameters

The indicated electrical parameters apply to the full operating range, unless otherwise specified. The typical values correspond to a supply voltage  $V_{DD} = 5.0\text{ V}$  and  $25^{\circ}\text{C}$ , unless individually specified. All other values correspond to  $-40^{\circ}\text{C} < T_J < 150^{\circ}\text{C}$ .

**Table 4 Electrical Parameters**

| Parameter                    | Symbol          | Limit Values |      |                   | Unit          | Notes   |
|------------------------------|-----------------|--------------|------|-------------------|---------------|---|
|                              |                 | min.         | typ. | max.              |               |   |
| Supply Current <sup>1)</sup> | $I_{DD}$        | -            | 15   | 20                | mA            | $V_{DD} = 4.5\text{ to }5.5\text{V}$                            |
|                              |                 | -            | -    | 21                |               | $V_{DD} = 6.5\text{ V}$   |
| POR Level                    | $V_{POR}$       | 2.0          | 2.3  | 2.9               | V             | Power On Reset  |
| POR Hysteresis               | $V_{PORhy}$     | -            | 30   | -                 | mV            |   |
| Power On Time                | $t_{Pon}$       | 50           | 100  | 200               | $\mu\text{s}$ | $V_{DD} > V_{DDmin}$ & after first edge on $f_{CLK}$            |
| PLL Jitter                   | $t_{PLLjit\_S}$ | -            | 1.3  | 2.0 <sup>2)</sup> | ns            | short term <sup>3)</sup>  |
|                              | $t_{PLLjit\_L}$ | -            | 3.0  | 3.9               |               | long term <sup>4)</sup>   |
| ADC Noise <sup>5)</sup>      | $N_{ADC}$       | -            | 1    | 2.2               | digits        | 1 $\sigma$ @ FIR_BYP = 0  |
|                              |                 | -            | 2    | 4.4 <sup>2)</sup> |               | 1 $\sigma$ @ FIR_BYP = 1  |
| Input Signal Low Level       | $V_L$           | -0.35        | -    | 0.3 $V_{DD}$      | V             | Tested only at DATA pin as structures of all pins are identical |
| Input Signal High Level      | $V_H$           | 0.7 $V_{DD}$ | -    | $V_{DD} + 0.35$   | V             |   |
| Capacitance of SSC Data Pin  | $C_{LDATA}$     | -            | 4    | 6 <sup>2)</sup>   | pF            | Internal  |

1) Without external pull-up resistor for SSC-Interface

2) Not tested

3) From pulse to pulse

4) Accumulated over 1 ms

5) ADC noise in respect to the peak ADC value specified in **“Signal Processing” on Page 23**.  
Noise tested using 1  $\sigma$  of 100 sample values from Angle Test “000”

**Electrical and Magnetic Parameters**
**Table 5 Electrical Parameters**

| Parameter               | Symbol   | Limit Values  |      |      | Unit    | Notes   |
|-------------------------|----------|---------------|------|------|---------|---|
|                         |          | min.          | typ. | max. |         |   |
| Input Hysteresis        | $V_{HY}$ | 0.07 $V_{DD}$ | -    | -    | V       |   |
| Pull-Up Current         | $I_{PU}$ | -10           | -    | -150 | $\mu$ A | $\overline{CS}$ , DATA                        |
| Pull-Down Current       | $I_{PD}$ | 15            | -    | 225  | $\mu$ A | SCK, CLK                                      |
|                         |          | 15            | -    | 225  |         | TST1  |
|                         |          | 10            | -    | 150  |         | TST2  |
| Output Signal Low Level | $V_{OL}$ | -             | -    | 0.7  | V       | $I_Q = -10$ mA<br>$I_Q = -5$ mA <sup>1)</sup> |
|                         |          | -             | -    | 0.4  |         |   |

<sup>1)</sup> The value -5 mA is not tested

Note: **Table 5** is valid for  $4.5V < V_{DD} < 5.5V$ .

**5.2 ESD Protection**
**Table 6 ESD Protection**

| Parameter   | Symbol    | Limit Values |           | Unit | Notes             |
|-------------|-----------|--------------|-----------|------|-------------------|
|             |           | min.         | max.      |      |                   |
| ESD Voltage | $V_{HBM}$ | -            | $\pm 2$   | kV   | HBM <sup>1)</sup> |
|             | $V_{SDM}$ | -            | $\pm 500$ | V    | SDM <sup>2)</sup> |

<sup>1)</sup> Human Body Model (HBM) according to: JEDEC EIA/JESD22-A114-B (R = 1.5 k $\Omega$ , C = 100 pF, T<sub>A</sub> = 25°C)

<sup>2)</sup> Socketed Device Model (SDM) according to: ESD ASS.STD.DS5.3-93



### 5.3 GMR Parameters

All parameters apply over the full operating range, unless otherwise specified.

**Table 7 Basic GMR Parameters**

| Parameter                      | Symbol     | Limit Values |       |             | Unit   | Notes                        |
|--------------------------------|------------|--------------|-------|-------------|--------|------------------------------|
|                                |            | min.         | typ.  | max.        |        |                              |
| X, Y Output range              | $RG_{ADC}$ | -            | -     | $\pm 23230$ | digits |                              |
| X, Y Amplitude <sup>1)</sup>   | $A_X, A_Y$ | 6000         | 12337 | 15781       | digits | @ Calibration Conditions     |
|                                |            | 3922         | -     | 20620       |        | Operating Range              |
| X, Y Synchronism <sup>2)</sup> | $k$        | 80           | 100   | 120         | %      | @ Calibration Conditions     |
| X, Y Offset <sup>3)</sup>      | $O_X, O_Y$ | -3000        | 0     | 3000        | digits | @ Calibration Conditions     |
| X, Y Orthogonality Error       | $\varphi$  | -10.0        | 0     | 10.0        | °      | @ Calibration Conditions     |
| X, Y without field             | $X_0, Y_0$ | -5000        | -     | 5000        | digits | without magnet <sup>4)</sup> |

1) See [Figure 4, Page 12](#)

2)  $k = 100 \times (A_X / A_Y)$ .

3)  $O_{SIN} = (Y_{MAX} + Y_{MIN}) / 2$ ;  $O_{COS} = (X_{MAX} + X_{MIN}) / 2$

4) Not tested.

#### 5.3.1 Offset and Amplitude

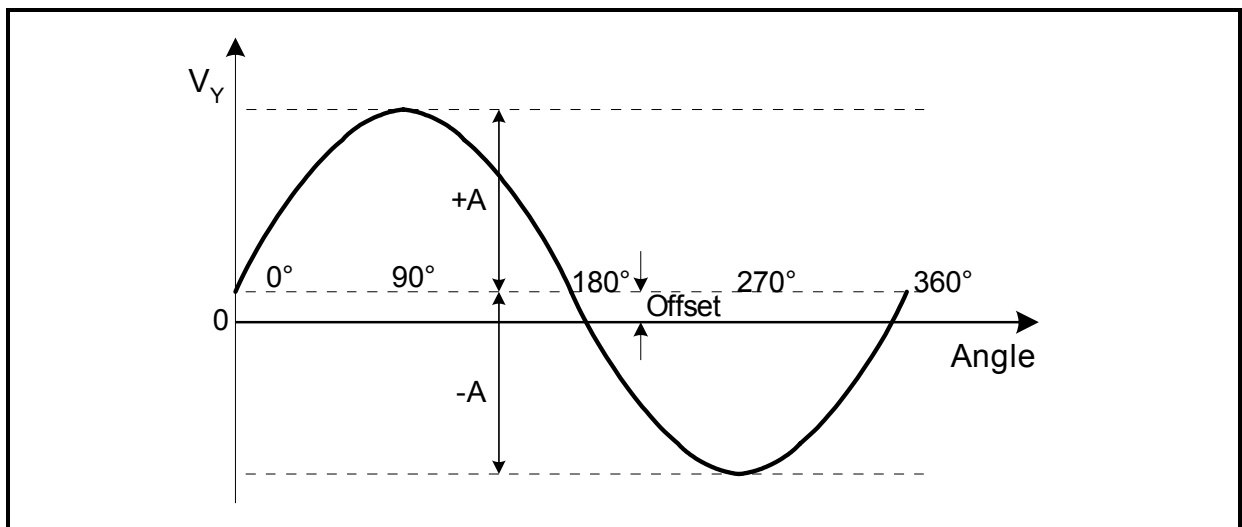

**Figure 5 Offset and Amplitude Definition**

**Electrical and Magnetic Parameters**
**Offset Definition**

The offset of the X and Y signals is defined as the mean value between the signed maximum and minimum values of the idealized sine or cosine wave.

$$O_X = \frac{X_{MAX} + X_{MIN}}{2}$$

$$O_Y = \frac{Y_{MAX} + Y_{MIN}}{2}$$

**Amplitude Definition**

The amplitude is defined as half the difference between the signed maximum and minimum values of the idealized sine or cosine wave.

$$A_X = \frac{X_{MAX} - X_{MIN}}{2}$$

$$A_Y = \frac{Y_{MAX} - Y_{MIN}}{2}$$

**5.3.2 Temperature dependent behavior**

The temperature offset gradients for both channels depend on the value at 25°C. The gradients can be calculated using following linear equations:

$$KT_{OX} = tco\_d\_x + (tco\_k\_x \times O_{X25})$$

$$KT_{OY} = tco\_d\_y + (tco\_k\_y \times O_{Y25})$$

$O_{X25}$ ,  $O_{Y25}$ : Offset values at 25°C in digits.

**Table 8 GMR Temperature Coefficients**

| Parameter                           | Symbol      | Limit Values |            |      | Unit        | Notes |
|-------------------------------------|-------------|--------------|------------|------|-------------|-------|
|                                     |             | min.         | typ.       | max. |             |       |
| Offset Temperature Coefficient Base | $tco\_d\_x$ | -            | +0.116296  | -    | digits / _K |       |
|                                     | $tco\_d\_y$ | -            | -0.079401  | -    |             |       |
| Offset Temperature Coefficient Gain | $tco\_k\_x$ | -            | -0.0010147 | -    | 1 / _K      |       |
|                                     | $tco\_k\_y$ | -            | -0.0010121 | -    |             |       |

**Electrical and Magnetic Parameters**

**Orthogonality Definition**

The corresponding maximum and zero crossing points of the SIN and COS signals do not occur at the precise distance of 90°. The difference between X and Y phase is called the '**Orthogonality Error**'.

$$\varphi = \varphi_X - \varphi_Y$$

$\varphi_{ideal} = 0^\circ$

$\varphi_X$  : Phase error of X (= cos) Signal

$\varphi_Y$  : Phase error of Y (= sin) Signal

**5.4 Calibration**

**GMR Values**

The end-of-line calibration can be accomplished using following sequence.

The conditions are specified in **Table 9**.

- Turn magnetic field **left** and measure X and Y values
- Calculation of Amplitude, Offset, Phase correction values of left turn
- Turn further 90° left and 90° back right without measurement
- Turn magnetic field **right** and measure X and Y values
- Calculation of Amplitude, Offset, Phase correction values of right turn
- Calculation of **mean** values of Amplitude, Offset, Phase correction values

The conditions are specified in **Table 9**.

The above gained values must be stored in a non-volatile memory. They are used for the correction of the read-out X and Y values before the angular calculation.

The resulting angular deviation is calculated using the above determined parameters.

**Temperature Measurement**

The signal amplitude  $T_{25}$  of the temperature measurement path at the calibration conditions must be measured and stored.

**Calibration Conditions**

All errors are related to calibration performed using following conditions:

**Table 9 GMR calibration conditions**

| Parameter    | Symbol    | Limit Values |      |      | Unit | Notes        |
|--------------|-----------|--------------|------|------|------|--------------|
|              |           | min.         | typ. | max. |      |              |
| Flux density | $B_{CAL}$ | -            | 50   | -    | mT   | $B_Z = 0$ mT |
| Temperature  | $T_{CAL}$ | -            | 25   | -    | °C   |              |

## 5.5 Angle Calculation

### 5.5.1 Components of the Output Signals

The X and Y signals at the output can be described by the following equations:

$$X = A_X \times \cos(\alpha + \varphi_X) + O_X$$

$$Y = A_Y \times \sin(\alpha + \varphi_Y) + O_Y$$

$A_X$  : Amplitude of X (= cos) Signal

$A_Y$  : Amplitude of Y (= sin) Signal

$O_X$  : Offset of X (= cos) Signal

$O_Y$  : Offset of Y (= sin) Signal

$\varphi_X$  : Phase error of X (= cos) Signal

$\varphi_Y$  : Phase error of Y (= sin) Signal

### 5.5.2 GMR Error Compensation

#### Temperature dependent Offset Value

To increase the accuracy, the temperature-dependent offset drift can be compensated. The temperature of the chip must be read out. The Offset values  $O_X$  and  $O_Y$  can be described by the following equations.

$$O_X = O_{X25} + \frac{KT_{OX}}{S_T} \times (T - T_{25})$$

$$O_Y = O_{Y25} + \frac{KT_{OY}}{S_T} \times (T - T_{25})$$

$O_{X25}$ ,  $O_{Y25}$  : Offset value at 25°C in digits

$T_{25}$  : Temperature value at 25°C in digits

$T$  : Temperature value in digits

$S_T$  : Sensitivity of the temperature measurement path, (see chapter [“Temperature Measurement” on Page 46](#)).

**Offset Correction**

After the X and Y values are read out, the temperature corrected offset value must be subtracted.

$$X_1 = X - O_X$$

$$Y_1 = Y - O_Y$$

**Amplitude Normalization**

Next, the X and Y values are normalized using the peak values determined in the calibration.

$$X_2 = \frac{X_1}{A_X}$$

$$Y_2 = \frac{Y_1}{A_Y}$$

**Non-Orthogonality Correction**

The influence of the non-orthogonality can be compensated using following equation, in which only the Y channel must be corrected.

$$Y_3 = \frac{Y_2 - X_2 \times \sin(-\varphi)}{\cos(-\varphi)}$$

**Resulting Angle**

After correction of all errors, the resulting angle can be calculated using the arctan function<sup>1)</sup>.

$$\alpha = \arctan\left(\frac{Y_3}{X_2}\right) - \varphi_X$$

<sup>1)</sup> Microcontroller function "arctan2(Y<sub>3</sub>,X<sub>2</sub>)" to resolve 360°

Electrical and Magnetic Parameters

**5.6 GMR Parameters after Calibration**

After calibration under the conditions specified in [Table 9 "GMR calibration conditions" on Page 19](#), the sensor has a remaining error as shown in [Table 10](#).

The error value refers to  $B_z = 0$  mT and operating conditions given in [Table 3 "Operating Range" on Page 14](#).

**Table 10 GMR Parameter with Temperature-Dependent Offset Compensation**

| Parameter     | Symbol         | Limit Values |            |      | Unit | Notes |
|---------------|----------------|--------------|------------|------|------|-------|
|               |                | min.         | typ.<br>1) | max. |      |       |
| Overall Error | $\alpha_{err}$ | -            | 0.7        | 1,6  | °    | 2) 3) |

1) At 25°C, B=50mT

2) Including hysteresis error

3) At 0h

## 6 Signal Processing

Table 11 Signal Processing

| Parameter  | Symbol               | Limit Values |                    |       | Unit          | Notes  |
|--|----------------------|--------------|--------------------|-------|---------------|--|
|  |                      | min.         | typ. <sup>1)</sup> | max.  |               |  |
| Internal Cutoff Frequency (-3dB) of sin or cos Value | $f_{\text{Cut-Off}}$ | -            | 4.9                | -     | kHz           | FIR_BYP=0  |
|  |                      |              | 19.6               |       |               | FIR_BYP=1  |
| Update Time of sin or cos Value <sup>2)</sup>        | $t_{\text{upd}}$     | -            | 81,9               | -     | $\mu\text{s}$ | FIR_BYP=0  |
|  |                      | -            | 20,5               | -     |               | FIR_BYP=1  |
| Settle Time <sup>3)</sup>                            | $t_{\text{settle}}$  | -            | 163,8              | -     |               | FIR_BYP=0  |
|  |                      | -            | 41,0               | -     |               | FIR_BYP=1  |
| Peak ADC Output value                                | $ADC_{\text{Pk}}$    | -            | -                  | 23230 | digits        | signed 16 bit integer (2s complement) <sup>4) 5)</sup><br>6) |

1) For 4 Mhz input frequency

2)  $t_{\text{upd}} = 8192 / (25 \times f_{\text{CLK}})$  for FIR\_BYP = 0  
 $t_{\text{upd}} = 8192 / (100 \times f_{\text{CLK}})$  for FIR\_BYP = 1

3)  $t_{\text{settle}} = 2 \times t_{\text{upd}}$ , after change of ADC input source

4) Output values are valid up to this limit. Above it, corrupted results may occur due to non-linearity of the ADC.

5) One digit represent typically 5.166  $\mu\text{V}$ .

6) Correspond to max. GMR output value.

## 7 Clock Supply (CLK Timing Definition)

The clock signal input “CLK” must fulfill certain requirements, as identified in this section:

- The high or low pulse width must not exceed the specified values, because the PLL needs a minimum pulse width and must be spike filtered.
- The duty cycle factor should be 0.5 but can deviate to the values limited by  $t_{CLKh(f\_min)}$  and  $t_{CLKl(f\_min)}$ .
- The PLL is triggered at the positive edge of the clock. If more than 2 edges are missing, a chip reset is generated automatically.

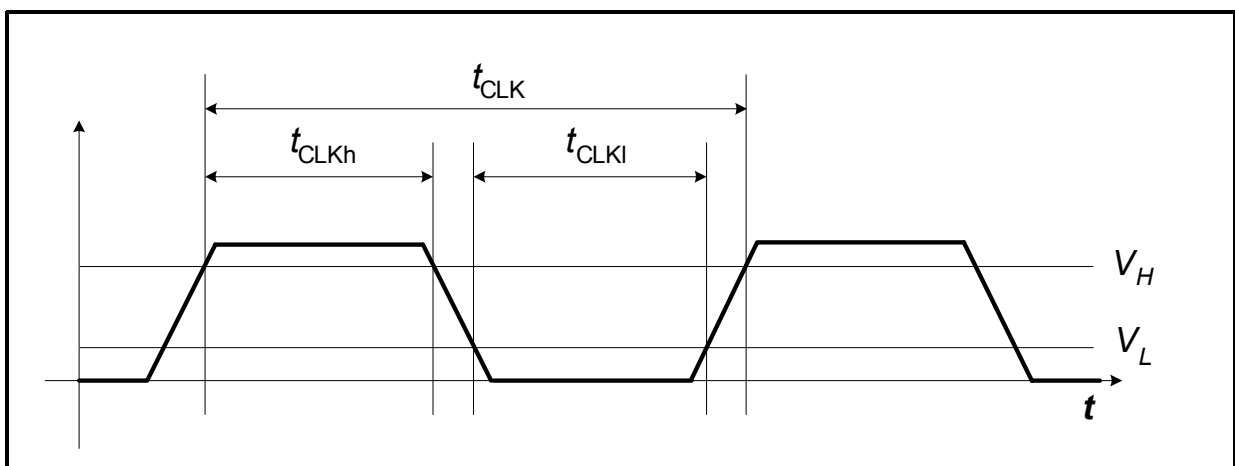

**Figure 6 CLK Timing Definition**

**Table 12 CLK Timing Specification**

| Parameter                    | Symbol       | Limit Values |      |      | Unit | Notes                |
|------------------------------|--------------|--------------|------|------|------|----------------------|
|                              |              | min.         | typ. | max. |      |                      |
| Input Frequency              | $f_{CLK}$    | 3.9          | 4.00 | 4.2  | MHz  |                      |
| CLK Duty Cycle <sup>1)</sup> | $CLK_{DUTY}$ | 30           | 50   | 70   | %    |                      |
| CLK rise time                | $t_{CLKr}$   | -            | -    | 20   | ns   | from $V_L$ to $V_H$  |
| CLK fall time                | $t_{CLKf}$   | -            | -    | 20   | ns   | from $V_H$ to $V_L$  |
| PLL Frequency                | $f_{PLL}$    | -            | 100  | -    | MHz  | $f_{CLK} * 25$       |
| Digital Clock                | $f_{DIG}$    | -            | 25   | -    | MHz  | $(25 / 4) * f_{CLK}$ |
| Digital Clock Period         | $t_{DIG}$    | -            | 40   | -    | ns   | $4 / (25 * f_{CLK})$ |

<sup>1)</sup> Minimum duty cycle factor:  $t_{CLKh(f\_min)} / t_{CLK(f\_min)}$  with  $t_{CLK(f\_min)} = 1 / f_{CLK(f\_min)}$   
 Maximum duty cycle factor:  $t_{CLKh(f\_max)} / t_{CLK(f\_min)}$  with  $t_{CLKh(f\_max)} = t_{CLK(f\_min)} - t_{CLKl(min)}$



Synchronous Serial Communication Interface (SSC)

## 8 Synchronous Serial Communication Interface (SSC)

The 3-pin Synchronous Serial Communication Interface (SSC) has a bidirectional data line (open drain), a serial clock signal and chip select.

The SSC Interface is designed to communicate with a microcontroller with bi-directional SSC interface supporting Open Drain. Other microcontrollers may require an external NPN transistor.

This allows communication with SPI-compatible devices.

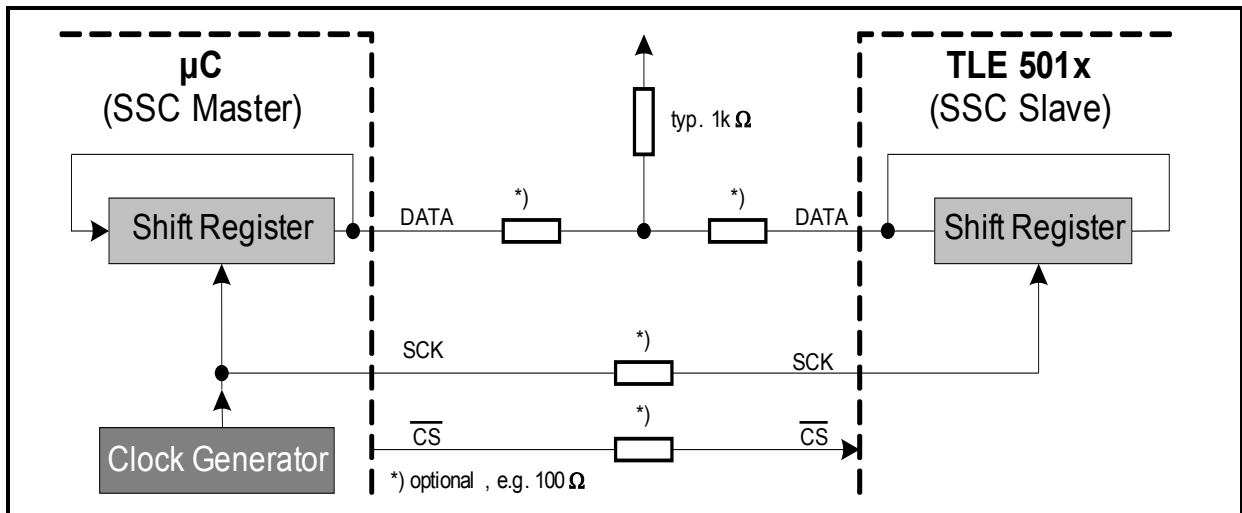

Figure 7 SSC Half-Duplex Configuration - Microcontroller with Open Drain

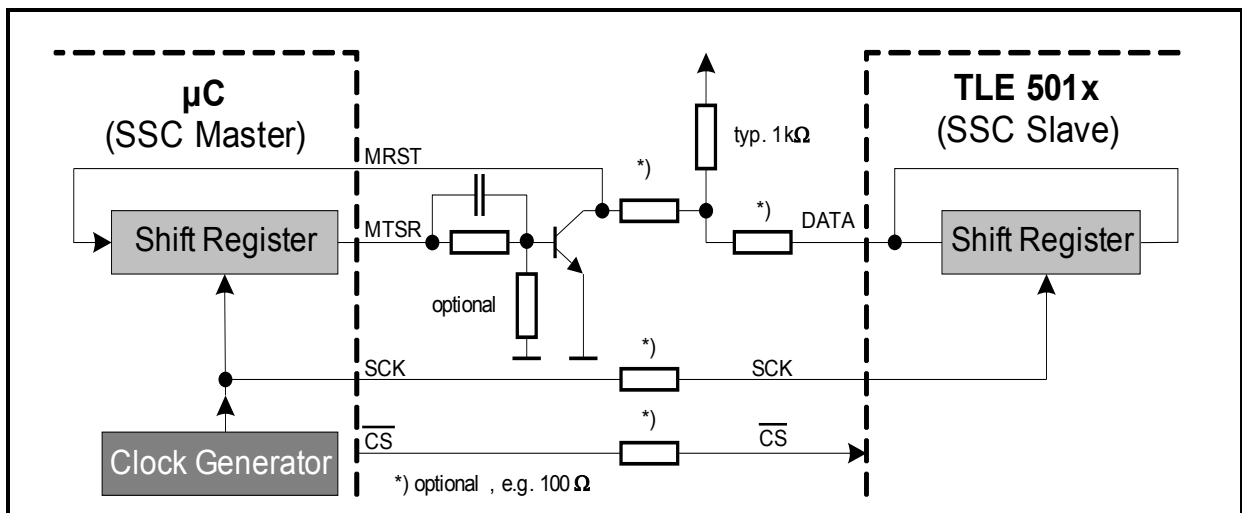

Figure 8 SSC Half-Duplex Configuration - Microcontroller without Open Drain

Synchronous Serial Communication Interface (SSC)

8.1 SSC Timing Definition

SSC Timing Diagram

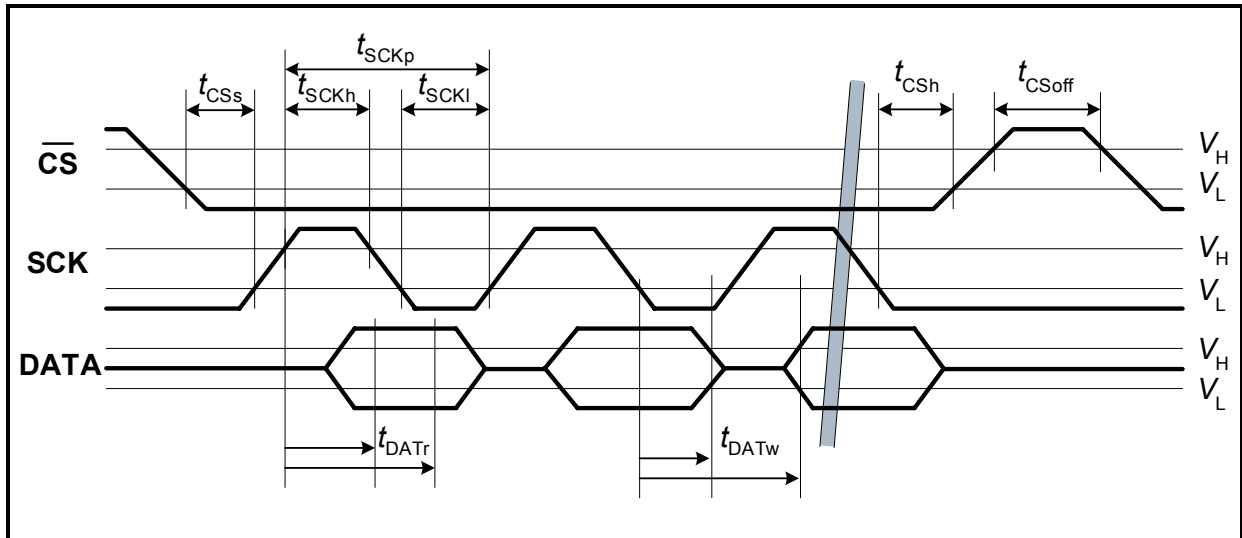

Figure 9 SSC Timing Definition

**SSC Inactive Time ( $\overline{CS}_{off}$ )**

The SSC inactive time defines the delay, before the TLE5011 can be selected again after a transfer. The TLE5011 reacts only to one command after SSC inactive time. Then the SSC Interface of the TLE5011 is disabled until the next SSC Inactive Time is performed.

**DATA Write Time ( $t_{DATw}$ )**

During this time the TLE5011 changes the data line, thus the data are invalid. The DATA Write Time values are defined without pull-up resistor.

**Pull-up Time Value ( $t_{pU}$ )**

The value in [Table 13 "SSC Timing Specification" on Page 27](#) is estimated with 60 ns.

**Synchronous Serial Communication Interface (SSC)**
**Table 13 SSC Timing Specification**

Note: Timings must be calculated according to [Table 12 "CLK Timing Specification" on Page 24](#)

| Parameter                                  | Symbol      | Limit Values           |      |                                      | Unit     | Notes                      |
|--|-------------|------------------------|------|--------------------------------------|----------|----------------------------|
|  |             | min.                   | typ. | max.                                 |          |                            |
| SSC Baud Rate                              | $f_{SSC}$   | -                      | 2.0  | 2.1 <sup>1)</sup>                    | MBit / s |                            |
| $\overline{CS}$ Setup Time                 | $t_{CSs}$   | $3 \cdot t_{DIG} + 10$ | -    | -                                    | ns       |                            |
| $\overline{CS}$ Hold Time                  | $t_{CSH}$   | $5 \cdot t_{DIG} + 10$ | -    | -                                    | ns       |                            |
| $\overline{CS}_{off}$                      | $t_{CSoff}$ | $10 \cdot t_{DIG}$     | -    | -                                    | ns       | SSC inactive time          |
| SCK High                                   | $t_{SCKh}$  | $5 \cdot t_{DIG}$      | -    | -                                    | ns       |                            |
| SCK Low                                    | $t_{SCKl}$  | $5 \cdot t_{DIG}$      | -    | -                                    | ns       |                            |
| DATA Read Time<br>(Data Valid Time)        | $t_{DATr}$  | $6 \cdot t_{DIG} - 10$ | -    | $7 \cdot t_{DIG} + 10$               | ns       | SSC_FILT = 0               |
|  |             | $5 \cdot t_{DIG} - 10$ | -    | $7 \cdot t_{DIG} + 10$               |          | SSC_FILT = 1               |
| DATA Write Time<br>(Data Valid Time)<br>2) | $t_{DATw}$  | $6 \cdot t_{DIG} + 25$ | -    | $7 \cdot t_{DIG} + 50$<br>+ $t_{PU}$ | ns       |                            |
| DATA slope                                 | $t_{DATs}$  | -                      | 20   | 30 <sup>3)</sup>                     | ns       | Falling edge <sup>4)</sup> |

1)  $f_{CLK}/2$ , synchronized to  $f_{CLK}$  if  $f_{CLK} = f_{CLK(max)}$

2)  $t_{PU}$  is the time generated by the pull-up resistor

3) Not tested.

4) Internal slope control of falling edge for data bit transition from  $V_H$  to  $V_L$ .

Synchronous Serial Communication Interface (SSC)

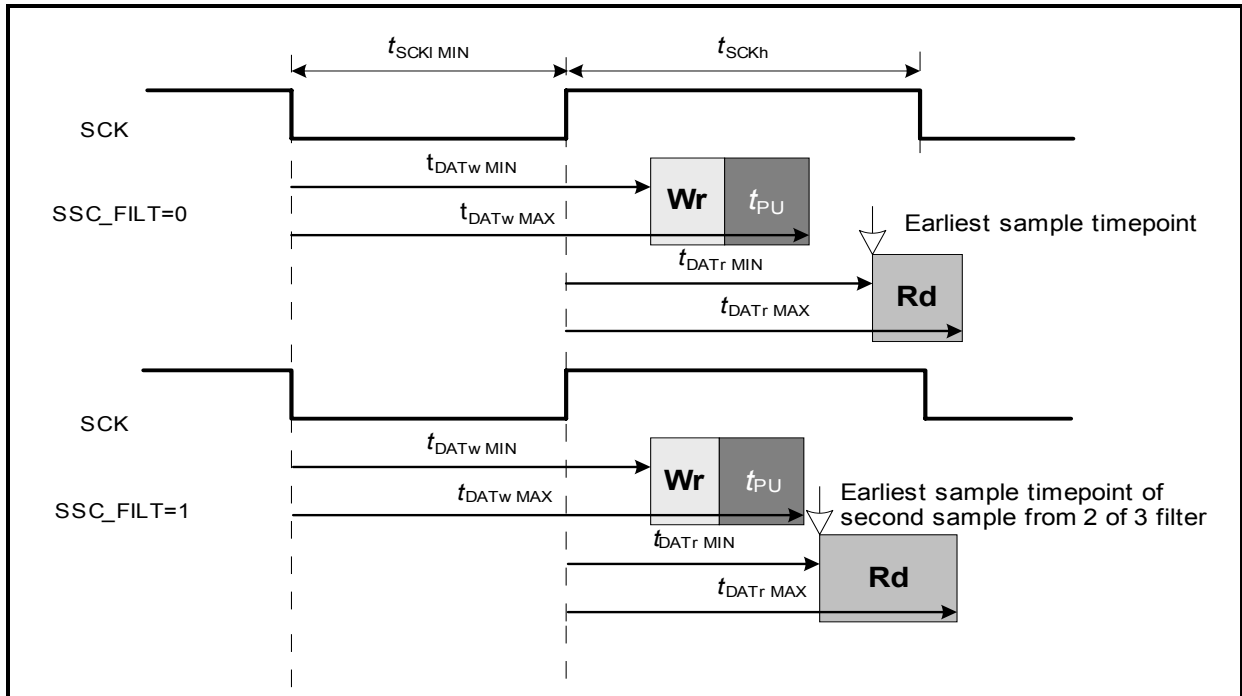

**Figure 10 SSC Interface Timing Details - Worst-Case Specified Timing**

*Note: The read window includes the sampling of the data bit. For  $SSC\_FILT = 1$ , the 2-of-3 selection is already considered. Only the two last data values need to be equal. For  $SSC\_FILT = 0$  only one sample point is selected.*

## Synchronous Serial Communication Interface (SSC)

The margin time shown in **Table 14** is the time between write access to the SSC Data Line and the earliest possible sample read of the TLE5011 itself for read back.

It is useful to have a maximum distance between the WRITE and subsequent READ. This ensures a reliable read back of the written data for the Slave-Active Byte generation.

**Table 14 Maximum Pull-up Time Margin with Worst-Case Specified Timing**

| SSC_FILT | SSC_TIMING | Min. $t_{PU}$ Margin <sup>1)</sup> | Unit | Comment |
|----------|------------|------------------------------------|------|---------|
| 0        | don't care | 90                                 | ns   |         |
| 1        |            | 50                                 |      |         |

<sup>1)</sup> Calculation:  $\text{Margin} = t_{SCKI(\min)} + t_{DATwMAX} - (t_{PU}) - t_{DATrMIN}$ . For Margin < 50 ns no problems can occur.

### 8.2 SSC Baud rate

The SSC Baud rate depends on the internal clock frequency.

12 internal digital clock cycles are necessary to ensure a reliable operation. Therefore, the maximum SSC Baud rate depends on the external CLK.

$$f_{SSC} = \frac{f_{CLK}}{2}$$

### 8.3 SSC Spike Filter

A SSC Spike Filter for all SSC lines can be selected via the **SSC\_FILT** bit.

#### 8.3.1 SSC Spike Filter Off

When the spike filter is disabled, each slope of a rising voltage is used to define a bit. This is independent of the length of the sampled pulse. For example, a positive spike generates a rising and a falling edge.

Synchronous Serial Communication Interface (SSC)

8.3.2 SSC Spike Filter On

A sliding window with four consecutive sample bits is analyzed.

The sample frequency is:

$$f_S = \frac{1}{f_{\text{DIGIT}}}$$

Rising Edge Detect for SCK

- After a rising edge (LH combination), at least one of the two following samples must be high. *Valid bit combinations: 0111, 0110, 0101.*
- A falling condition must be detected before.

Falling Edge Detect for SCK

- After a falling edge (HL combination), at least one of the two following samples must be low. *Valid bit combinations: 1000, 1001, 1010.*
- A rising condition must be detected before.

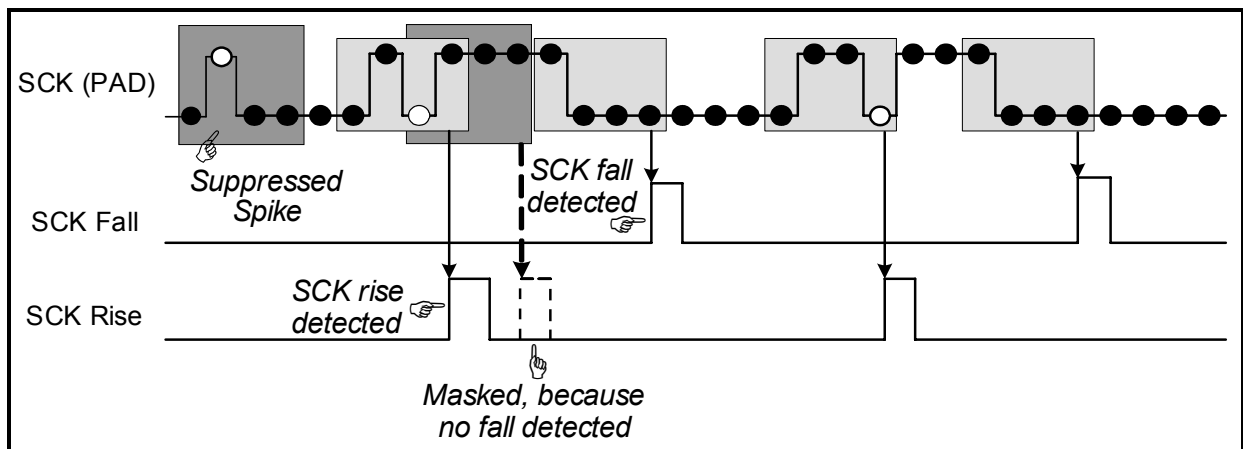

Figure 11 SSC Spike Filter

Filter for DATA and  $\overline{\text{CS}}$

The following conditions apply:

- The DATA pin has a '2-of-3' filter.
- The  $\overline{\text{CS}}$  input has a '2-of-3' filter, which suppresses only positive spikes.

**Synchronous Serial Communication Interface (SSC)**

**8.4 SSC Data Transfer**

The following transfer bytes are possible:

- Command byte (to access and change operating modes of the TLE5011)
- Data bytes (any data transferred in any direction)
- CRC byte (cyclic redundancy check)
- Slave Active byte (response of all selected slaves)

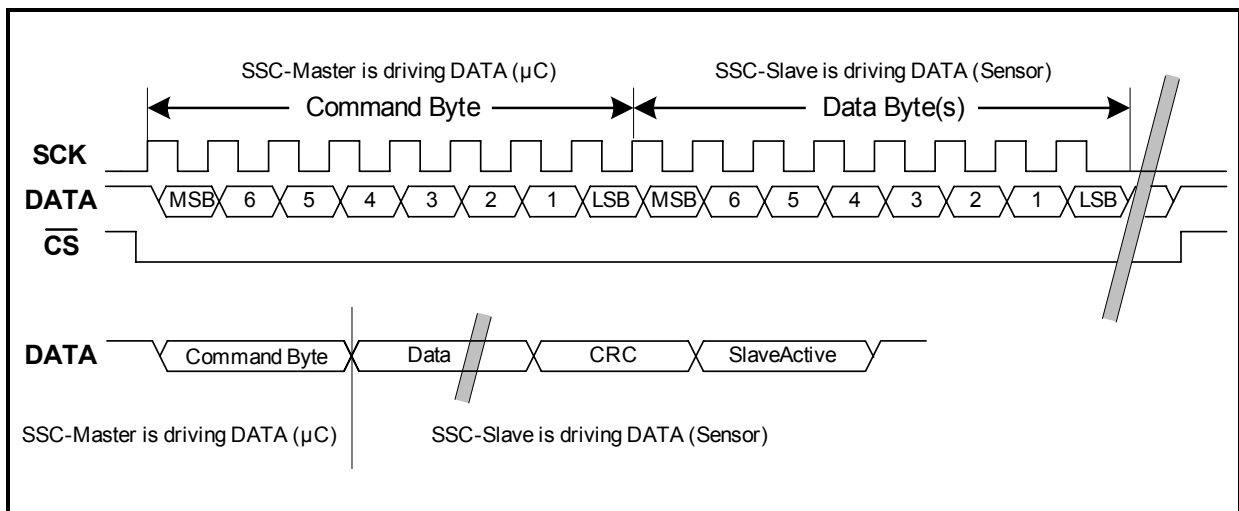

**Figure 12 SSC Data Transfer (Data Read Example)**

**8.5 SSC Command Byte**

The TLE5011 is controlled by a command byte. It is sent first at every data transmission.

**Table 15 Structure of the Command Byte**

| Name | Bits   | Description   |
|------|--------|---|
| RW   | [7]    | Read - Write<br>0 = write, 1 = read   |
| ADDR | [6..3] | Address to be read / written<br>0..15 - register start address (address auto increment) |
| ND   | [2..0] | Number of data bytes 0..7 - number of data bytes to be transferred                      |

## 9 Register Table

This chapter defines the complete address range as well as all registers of the TLE5011. It also defines the read/write access rights of the specific registers. **Table 16** identifies the values with symbols. Access to the registers is accomplished via the SSC Interface.

**Table 16 Address Map**

| Addr.           | Name      | Bits              |         |          |          |          |         |         |          |
|-----------------|-----------|-------------------|---------|----------|----------|----------|---------|---------|----------|
|                 |           | 7                 | 6       | 5        | 4        | 3        | 2       | 1       | 0        |
| 00 <sub>H</sub> | CTRL1     | -                 | -       | -        | -        | SSC_FILT | -       | AUTO    | UR       |
| 01 <sub>H</sub> | XL        | X <sub>Low</sub>  |         |          |          |          |         |         |          |
| 02 <sub>H</sub> | XH        | X <sub>High</sub> |         |          |          |          |         |         |          |
| 03 <sub>H</sub> | YL        | Y <sub>Low</sub>  |         |          |          |          |         |         |          |
| 04 <sub>H</sub> | YH        | Y <sub>High</sub> |         |          |          |          |         |         |          |
| 05 <sub>H</sub> | FCNT_STAT | -                 | STAT_VR | GMR_OFF  | UPDATE   | FCNT     |         |         |          |
| 06 <sub>H</sub> | FSYNC_INV | FILT_INV          | FSYNC   |          |          |          |         |         |          |
| 07 <sub>H</sub> | ANGT      | -                 | ANGT_EN | ANGT_Y   |          |          | ANGT_X  |         |          |
| 08 <sub>H</sub> | -         | reserved          |         |          |          |          |         |         |          |
| 09 <sub>H</sub> | -         | reserved          |         |          |          |          |         |         |          |
| 0A <sub>H</sub> | -         | reserved          |         |          |          |          |         |         |          |
| 0B <sub>H</sub> | -         | reserved          |         |          |          |          |         |         |          |
| 0C <sub>H</sub> | TST       | TEMP_EN           | ADCPY   | FILT_PAR | FILT_CRS | FILT_BYP | TST_ADC | TST_GMR | TST_CHAN |
| 0D <sub>H</sub> | ID        | DEV_ID            |         |          |          | REV_ID   |         |         |          |
| 0E <sub>H</sub> | LOCK      | LOCK              |         |          |          |          |         |         |          |
| 0F <sub>H</sub> | CRTL2     | VDD_OV            | VDD_OFF | GND_OFF  | VRG_OV   | VRA_OV   | VRD_OV  | S_NO    |          |



**Bit Types**

The types of bits used in the registers are listed here:

| <b>Abbreviation</b> | <b>Function</b> | <b>Description</b>  |
|---------------------|-----------------|---|
| L                   | Locked          | Locked register.<br>Locked registers can be written only when the unlock-value is written in the lock register ( <b>0E<sub>H</sub></b> ). This ensures that these bits cannot be modified unintentionally during normal operation.  |
| U                   | Update          | Update-Buffer for this bit is present.<br>In the case of an Update Command and the Update-Mode bit (UR in CTRL1) is set, the immediate values are stored in this Update-Buffer simultaneously. This enables a snapshot of all necessary system parameters at the same time. |
| S                   | Status          | Reset only after readout  |
| R                   | Read            | Read-only registers   |
| W                   | Write           | Read and write registers  |

**Register Table**
**CTRL1**
**Addr: 00<sub>H</sub>**
**Reset Value: 01<sub>H</sub>**

|          |          |          |          |          |          |      |     |
|----------|----------|----------|----------|----------|----------|------|-----|
| 7        | 6        | 5        | 4        | 3        | 2        | 1    | 0   |
| reserved | reserved | reserved | reserved | SSC_FILT | reserved | AUTO | UR  |
| -        | -        | -        | W L      | W L      | -        | W L  | W L |

| Field    | Bits | Type | Description  |
|----------|------|------|--|
| reserved | 7    | -    | Reserved, must be set to 0   |
| reserved | 6    | -    | Reserved, must be set to 0   |
| reserved | 5    | -    | Reserved, must be set to 0   |
| reserved | 4    | -    | Reserved, must be set to 0   |
| SSC_FILT | 3    | W L  | SSC Digital Spike Filter enable for all SSC lines ( $\overline{CS}$ , CLK and DATA )<br>0: Digital SSC Spike filters off<br>1: Digital SSC Spike filters on (modified timing)  |
| reserved | 2    | -    | Reserved, must be set to 0   |
| AUTO     | 1    | W L  | Automatic update at angle tests<br>0: no automatic update in Angle Test Mode<br>1: automatic update-command after $t_{settle}$ , counters FSYNC and FCNT are reset to 0. Then the Angle-Test (ANGT_EN) is automatically disabled and switches back to normal operation.<br>Also, the UPDATE bit is toggled |
| UR       | 0    | W L  | Update / Run Mode<br>0: Run Mode (Buffer1 values are immediate values)<br>1: Update Mode (Buffer2 values are stored values)  |

Register Table

The values in Register 01H to 04H represent one byte of two's complement signed 16 bit integer values.

**X\_L**

**Addr: 01<sub>H</sub>**

**Reset Value: 00<sub>H</sub>**

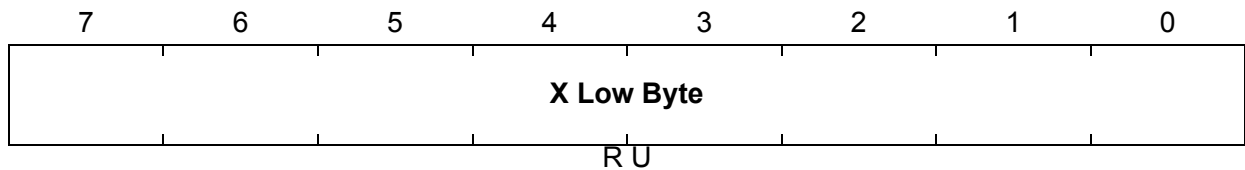

**X\_H**

**Addr: 02<sub>H</sub>**

**Reset Value: 00<sub>H</sub>**

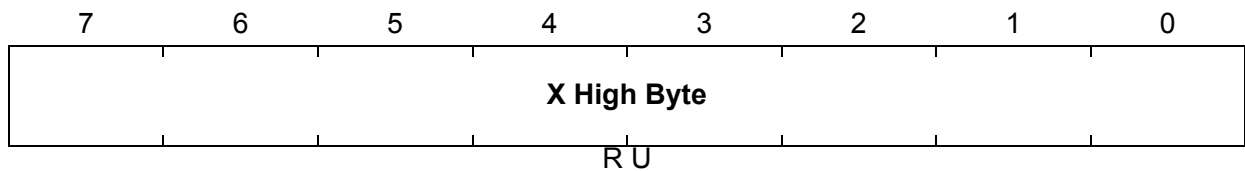

**Y\_L**

**Addr: 03<sub>H</sub>**

**Reset Value: 00<sub>H</sub>**

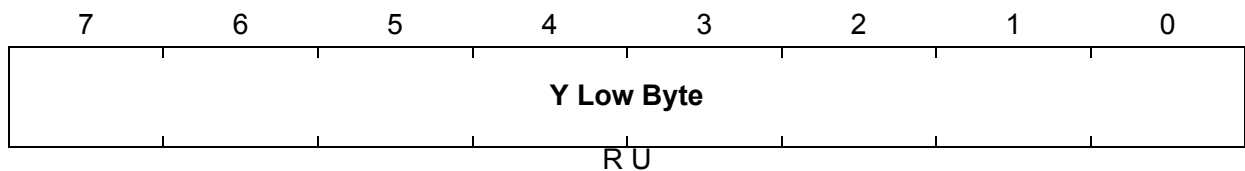

**Y\_H**

**Addr: 04<sub>H</sub>**

**Reset Value: 00<sub>H</sub>**

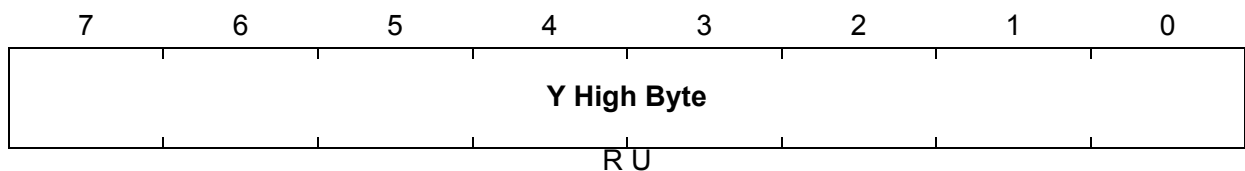

**Register Table**
**FCNT\_STAT**
**Addr: 05<sub>H</sub>**
**Reset Value: 80<sub>H</sub>**

|          |         |         |        |      |   |   |   |
|----------|---------|---------|--------|------|---|---|---|
| 7        | 6       | 5       | 4      | 3    | 2 | 1 | 0 |
| reserved | STAT_VR | GMR_OFF | UPDATE | FCNT |   |   |   |
| -        | RS      | RU      | RS     | RU   |   |   |   |

| Field    | Bits | Type | Description   |
|----------|------|------|---|
| reserved | 7    | -    |   |
| STAT_VR  | 6    | RS   | Voltage Regulator Status<br>This bit is a logical OR combination of Digital, Analog, GMR and VDD <sub>OV</sub> Comparator and GND <sub>OFF</sub> , and VDD <sub>OFF</sub> Comparator outputs.<br>0: Voltage Supply OK<br>1: Voltage Supply is not OK  |
| GMR_OFF  | 5    | RU   | ADC Values are no GMR values (e.g.: Temperature measurement is active)<br>This bit indicates, whether GMR values or any other values are connected to the ADCs. This value is read back from the multiplexer control signals.<br>0: X,Y Values are GMR values<br>1: X,Y Values normally represent temperature measurement or angle test values. In the case of non-functional MUX, this bit is set to 1   |
| UPDATE   | 4    | RU   | Update Toggle bit. This bit toggles after every update (update command or automatic update at angle test)<br>The bit is independent of UR bit in CTRL1  |
| FCNT     | 3-0  | RU   | Frame Counter (4-bit unsigned integer value)<br>This counter counts every new X,Y value pair coming out of the data path. (approx. 80µs)<br>This counter is reset to 0 <sub>H</sub> after any write to FSYNC and after every change of the ANGT_EN bit. As $t_{settle}$ time has to be waited for valid X,Y data, this counter must be $\geq 2_{\text{H}}$ to indicate valid X,Y values. If it overflows, it resets to 3 <sub>H</sub> to show, that values are still valid.<br><i>Note: If FIR_BYF is activated, this counter counts four times faster!</i> |

**Register Table**
**FSYNC\_INV**
**Addr: 06<sub>H</sub>**
**Reset Value: 00<sub>H</sub>**

|                 |   |   |   |   |   |   |    |
|-----------------|---|---|---|---|---|---|----|
| 7               | 6 | 5 | 4 | 3 | 2 | 1 | 0  |
| <b>FILT_INV</b> |   |   |   |   |   |   |    |
| WU              |   |   |   |   |   |   | WU |

| Field    | Bits | Type | Description   |
|----------|------|------|---|
| FILT_INV | 7    | WU   | Filter Input Inversion (to check the digital data path during operation)<br>0: Filter Inputs are not inverted<br>1: Filter Inputs are inverted  |
| FSYNC    | 6-0  | WU   | Frame Synchronization (7bit unsigned integer value)<br>The Filter Update time of approx. 80 μs results from the filter decimation. The phase of this decimation can be set and checked by this counter.<br>If FIR_BYF is activated, this counter overflows at the value 31 <sub>D</sub> . |

**ANGT**
**Addr: 07<sub>H</sub>**
**Reset Value: 00<sub>H</sub>**

|          |                |               |   |   |               |   |   |
|----------|----------------|---------------|---|---|---------------|---|---|
| 7        | 6              | 5             | 4 | 3 | 2             | 1 | 0 |
| reserved | <b>ANGT_EN</b> | <b>ANGT_Y</b> |   |   | <b>ANGT_X</b> |   |   |
| -        | W              | W             |   |   | W             |   |   |

| Field    | Bits | Type | Description   |
|----------|------|------|---|
| reserved | 7    | -    | Reserved, must be set to 0  |
| ANGT_EN  | 6    | W    | Angle Test Enable<br>0: Angle Test disable command<br>1: Angle Test enable command<br>in this case X and Y values represent resistive test values, which can be used to simulate angle values |
| ANGT_Y   | 5-3  | W    | Angle Test X and Y value  |
| ANGT_X   | 2-0  | W    | See : <a href="#">Table 17 "Functional Angle Test" on Page 45</a>   |

**Reserved Registers (08<sub>H</sub> to 0B<sub>H</sub>)**

The values in these registers are 8-bit unsigned integer values.

The values in addr.8 and addr.9 have to be in reset status.

**Reserved**

**Addr: 08<sub>H</sub>**

**Reset Value: FF<sub>H</sub>**

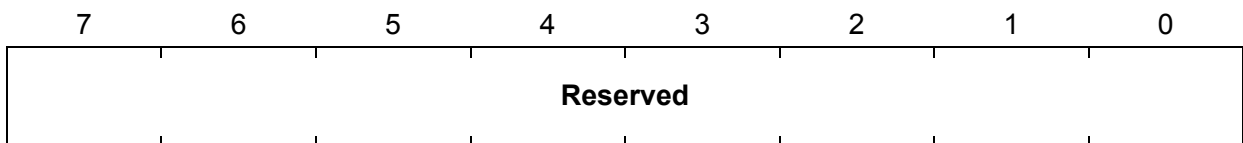

**Reserved**

**Addr: 09<sub>H</sub> - 0B<sub>H</sub>**

**Reset Value: 00<sub>H</sub>**

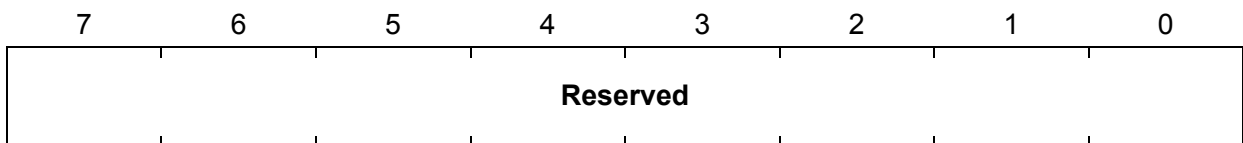

**Register Table**
**TST**
**Addr: 0C<sub>H</sub>**
**Reset Value: 00<sub>H</sub>**

|                |              |                 |                 |                |                |                |                 |
|----------------|--------------|-----------------|-----------------|----------------|----------------|----------------|-----------------|
| 7              | 6            | 5               | 4               | 3              | 2              | 1              | 0               |
| <b>TEMP_EN</b> | <b>ADCPY</b> | <b>FILT_PAR</b> | <b>FILT_CRS</b> | <b>FIR_BYP</b> | <b>TST_ADC</b> | <b>TST_GMR</b> | <b>TST_CHAN</b> |
| W L            | W L          | W L             | W L             | W L            | W L            | W L            | W L             |

| Field                 | Bits | Type | Description   |
|-----------------------|------|------|---|
| TEMP_EN               | 7    | W L  | Temperature Device Enable<br>0: Temperature Measurement disabled<br>1: Temperature Measurement enabled<br>The X value represents the temperature.<br>Automatic update mode enabled, if AUTO=1 |
| ADCPY                 | 6    | W L  | Y Polarity<br>0: No inversion of Y bit stream<br>1: Inversion of Y bit stream (rotating direct. changed)  |
| FILT_PAR              | 5    | W L  | Filter switched parallel<br>0: Filters in normal mode<br>1: Filters parallel, input selected by TST_CHAN  |
| FILT_CRS              | 4    | W L  | Filter switched across<br>0: Filters in normal mode<br>1: Filters crossed, X and Y outputs are exchanged  |
| FIR_BYP               | 3    | W L  | FIR Filter Bypass<br>0: No FIR Bypass<br>1: FIR Bypass  |
| TST_ADC <sup>1)</sup> | 2    | W L  | ADC input switch to TST1and TST2<br>0: No ADC input switch, normal operation<br>1: ADC input switched to TST1,2, ADC selected by TST_CHAN <sup>2)</sup>                                       |
| TST_GMR <sup>1)</sup> | 1    | W L  | GMR switch to TST1and TST2<br>0: No GMR switch, normal operation<br>1: GMR switched to TST1,2 <sup>2)</sup>   |
| TST_CHAN              | 0    | W L  | Test Channel select<br>0: X channel linked to TST1and TST2<br>1: Y channel linked to TST1and TST2   |

<sup>1)</sup> Only for test purposes

<sup>2)</sup> if TST\_ADC and TST\_GMR are set to 1 at the same time, TST\_GMR is forced to 0. TST\_ADC has the higher priority.

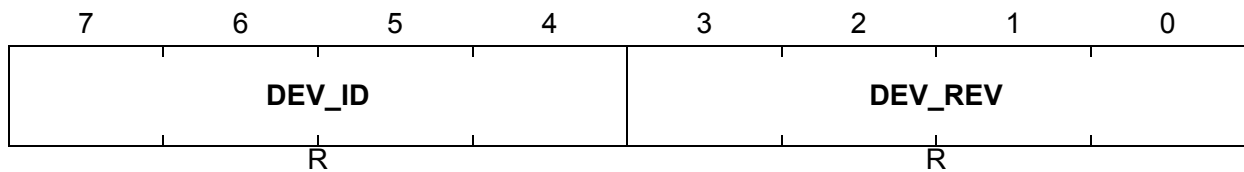
**Register Table**
**ID**
**Addr: 0D<sub>H</sub>**
**Reset Value: 12<sub>H</sub>**

| Field   | Bits | Type | Description  |
|---------|------|------|--|
| DEV_ID  | 7-4  | R    | Device Identifier<br>001 <sub>H</sub> : TLE5011 productive chip  |
| DEV_REV | 3-0  | R    | Device Revision (current number)<br>00 <sub>H</sub> : TLE5011 productive chip, 1st revision (B11)<br>01 <sub>H</sub> : TLE5011 productive chip, 2nd revision (B21)<br>02 <sub>H</sub> : TLE5010 productive chip, 3rd revision (B31)<br>03 <sub>H</sub> : TLE5010 productive chip, 4th revision (B41)<br>(Referred to Errata Sheets for later versions) |

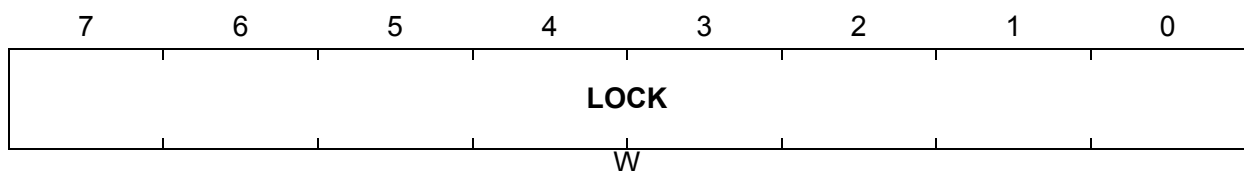
**LOCK**
**Addr: 0E<sub>H</sub>**
**Reset Value: 00<sub>H</sub>**

| Field | Bits | Type | Description   |
|-------|------|------|---|
| LOCK  | 7-0  | W    | Lock Byte<br>≠ 5A <sub>H</sub> : Lock registers locked<br>= 5A <sub>H</sub> : Lock registers unlocked |

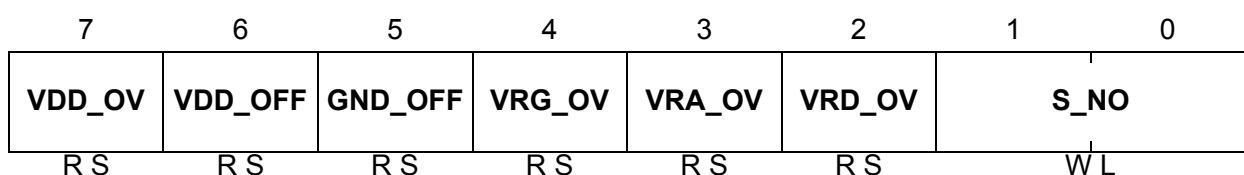
**CTRL2**
**Addr: 0F<sub>H</sub>**
**Reset Value: 00<sub>H</sub>**



**Register Table**

| Field   | Bits | Type | Description   |
|---------|------|------|---|
| VDD_OV  | 7    | R S  | V <sub>DD</sub> Overvoltage Comparator<br>0: No V <sub>DD</sub> Overvoltage occurred<br>1: V <sub>DD</sub> Overvoltage occurred |
| VDD_OFF | 6    | R S  | V <sub>DD</sub> - Off Comparator<br>0: No V <sub>DD</sub> - Off occurred<br>1: V <sub>DD</sub> - Off occurred                   |
| GND_OFF | 5    | R S  | GND - Off Comparator<br>0: No GND - Off occurred<br>1: GND - Off occurred   |
| VRG_OV  | 4    | R S  | GMR Voltage Regulator Overvoltage Comparator<br>0: Voltage ok<br>1: VRG Overvoltage occurred                                    |
| VRA_OV  | 3    | R S  | Analog Voltage Regulator Overvoltage Comparator<br>0: Voltage ok<br>1: VRA Overvoltage occurred                                 |
| VRD_OV  | 2    | R S  | Digital Voltage Regulator Overvoltage Comparator<br>0: Voltage ok<br>1: VRD Overvoltage occurred                                |
| S_NO    | 1-0  | W L  | Slave Number<br>Used in the SSC protocol  |

## 10 Data Communication via SSC

Data communication via the SSC Interface has the following characteristics:

- The data transmission order is “Most Significant Bit (MSB) first”.
- Data is put on the data line with the rising edge on SCK and read with the falling edge on SCK.
- The SSC Interface is byte-aligned. All functions are activated after each transmitted byte.
- A “high” condition on the negated Chip Select pin ( $\overline{CS}$ ) of the selected TLE5011 interrupts the transfer immediately. The CRC calculator is automatically reset.
- Every access to the TLE5011 with the number of data (ND)  $\geq 1$  is performed with address auto-increment.
- After an auto-increment overflow, the addresses begin from 00<sub>H</sub>.
- For every data transfer with ND  $\geq 1$ , an 8-bit CRC byte will be appended by the selected TLE5011. No CRC byte is sent in a data transfer with ND = 0 (e.g. Update Command).
- After the CRC byte is sent, the bit represented by S\_NO is pulled low by the selected slave in the Slave-Active-Byte (bits [3..0], low nibble). In this way, also broadcast-messages also produce individual feedback of every selected slave. This is necessary to differentiate the individual TLE5011 slave response, because the CRC byte is written by both TLE5011 in parallel.
- If the CRC byte on the bus is the same as the internally generated CRC of each TLE5011, each slave pulls the dedicated bit in the Slave-Active-Byte (bits [7..4], high nibble) low. If not, the bit in the high nibble remains 1.
- A write command to address 00<sub>H</sub> with ND = 0 will update all values inside the TLE5011, and only in this case can the transfer proceed. Furthermore, this command is add to the CRC-calculation of the following SSC Transfer.
- A command of 0000\_0000 is called **Update Command**. This command transfers the present immediate values of each register to the update register. After an Update Command, the  $\overline{CS}$  line does not need to set and reset again.
- The transfer ends after the CRC and Slave-Active byte have been sent. The TLE5011 always sends logical 1 and all following sent bits from the SSC Master are ignored (TLE5011 is in Idle mode). To enable data transfers again, the Chip Select pin (CS) of the TLE5011 must be deselected for  $\overline{CS}_{off}$  (see **Table 13**) once.
- If the Update Mode is selected (CTRL register, UR = 1), all accesses are performed to update registers where update registers are present. Other registers are accessed directly.

## 10.1 CRC Generation

This section identifies the requirements for CRC generation:

- This CRC is defined according to the *J1850* Bus-Specification of 15.Feb.1994 for Class B Data Communication.
- Every new transfer resets the CRC generation.
- Every byte of a transfer will be taken into account to generate the CRC (also the sent command(s)).
- Generator Polynomial:  $X^8+X^4+X^3+X^2+1$ , the fast CRC generation circuit is used for CRC generation. (See **Figure 13**)
- The remainder of the fast CRC circuit is initially set to  $11111111_B$ .
- The remainder is bit inverted before transmission.

**Figure 13** shows the fast CRC Polynomial.

The zero extension for initial CRC calculation is included!

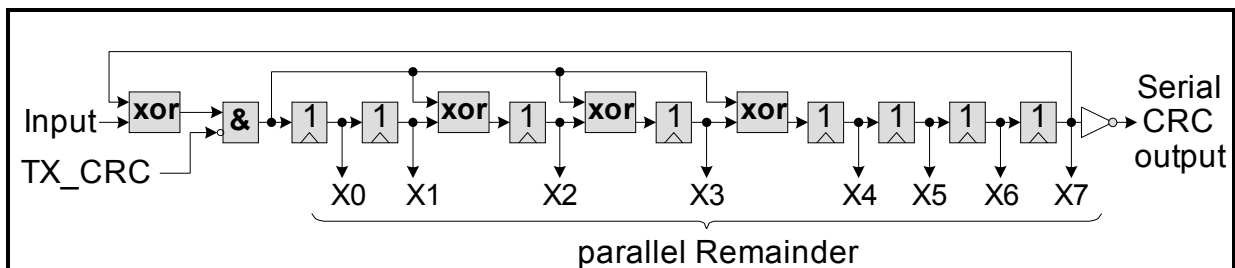

**Figure 13 Fast CRC Polynomial Division Circuit**

## 10.2 Slave Active Byte Generation

The position of the 0 in a nibble corresponds to the given slave number.

The slave active byte (cccc\_nnnn) consists of:

- **low nibble** (nnnn). One 0 is generated always according to the slave number.
- **high nibble** (cccc). The 0 is only generated, if the readback CRC is correct.

Slave1:  $S\_NO = 0 \Rightarrow$  bit 0 is pulled low      Slave Active Byte: 1110\_1110

Slave2:  $S\_NO = 1 \Rightarrow$  bit 1 is pulled low      Slave Active Byte: 1101\_1101

Slave3:  $S\_NO = 2 \Rightarrow$  bit 2 is pulled low      Slave Active Byte: 1011\_1011

Slave4:  $S\_NO = 3 \Rightarrow$  bit 3 is pulled low      Slave Active Byte: 0111\_0111

*Example for a communication disturbed by other bus participants:*

Slave1:  $S\_NO = 0 \Rightarrow$  bit 0 is pulled low, but the high nibble remains as '1111'.

> Slave Active Byte: 1111\_1110

**Example: Update X and Y and set ADC-Test Mode**

```

Command   Data       CRC (init all '0')
00000001    00000101    00000000
-----
xor 11111111
-----
=11111110.0      .      .A
xor 10001110.1   .      .
-----.-        .      .
= 01110000.10   .      .B
xor 1000111.01   .      .
-----.-        .      .
= 0110111.110   .      .C
xor 100011.101   .      .
-----.-        .      .
= 10100.0110    .      .D
xor 10001.1101   .      .
-----.-        .      .
= 00101.101101  .      .E
xor 100.011101   .      .
---.-          .      .
= 001.11000001. .      .F
xor 1.00011101.  .      .
---.-          .      .
=.11011100.0    .      .G
xor.10001110.1  .      .
.-.-.-.-.-.-.- .      .
= 1010010.10    .      .H
xor 1000111.01   .      .
-----.-        .      .
= 10101.1100    .      .I
xor 10001.1101   .      .
-----.-        .      .
= 100.000100    .      .J
xor 100.011101   .      .
---.-          .      .
=01100100.      Remainder
10011011        inverted Remainder

Transmitted Sequence:
Command  Data      CRC
00000001 00000101 10011011

```

## 11 Test Structures

Two different test signal structures are implemented in the TLE5011. These are:

- Functional Angle Test. In this case, well-known signals feed the ADCs.
- Temperature Measurement. This is useful to read out the chip temperature for compensation purposes.

### 11.1 Functional Angle Tests

It is possible to feed the ADCs with appropriate values to simulate a certain magnet-position and other GMR effects.

The values are generated with resistors on the chip.

Following X / Y ADC values can be programmed:

- 4 points, circle amplitude = 70.7%  
(0°, 90°, 180°, 270°)
- 8 points, circle amplitude = 100.0%  
(0°, 45°, 90°, 135°, 180°, 225°, 270°, 315°)
- 8 points, circle amplitude = 122.1%  
(35.3°, 54.7°, 125.3°, 144.7°, 215.3°, 234.7°, 305.3°, 324.7°)
- 4 points, circle amplitude = 141.4%  
(45°, 135°, 225°, 315°)

*Note: The 100% values typically correspond to 21700 digits and a voltage of ~ 110 mV.*

**Table 17 Functional Angle Test**

| Register Bits     | X / Y Values (decimal) |        |        |
|-------------------|------------------------|--------|--------|
|                   | min.                   | typ.   | max.   |
| 000               | -400                   | 0      | 400    |
| 001               | 14800                  | 15500  | 16200  |
| 010               | 20700                  | 21700  | 22700  |
| 011               | 32767                  |        |        |
| 100 <sup>1)</sup> | -400                   | 0      | 400    |
| 101               | -16200                 | -15500 | -14800 |
| 110               | -22700                 | -21700 | -20700 |
| 111               | -32768                 |        |        |

<sup>1)</sup> Not allowed to use.

ADC Test Vectors

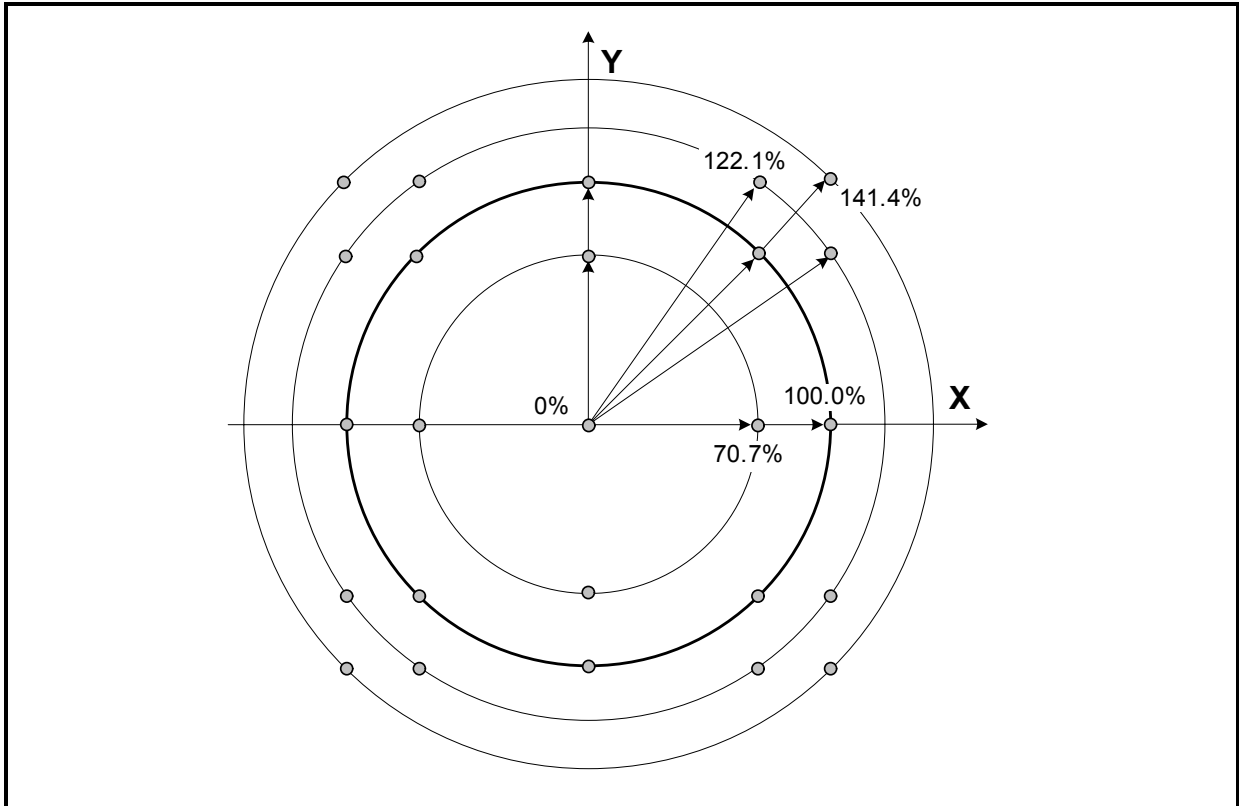

Figure 14 ADC Test Vectors

### 11.2 Temperature Measurement

An internal bandgap voltage can be used to measure the temperature on the chip. This may be used to compensate temperature-dependent errors.

The temperature values is sent out instead of the X value.

Table 18 Temperature Measurement

| Parameter               | Symbol    | Limit Values |         |        | Unit    | Notes         |
|-------------------------|-----------|--------------|---------|--------|---------|---------------|
|                         |           | min.         | typ.    | max.   |         |               |
| Value at -40°C          | $T_{-40}$ | -            | -       | +22000 | digits  |               |
| Value at 25°C           | $T_{25}$  | +2550        | +5775   | +9000  | digits  |               |
| Value at 150°C          | $T_{150}$ | -22000       | -       | -      | digits  |               |
| Temperature Sensitivity | $S_T$     | -            | -188.75 | -      | dig / K | <sup>1)</sup> |

<sup>1)</sup> Should be used for temperature compensation of offset errors

### 11.3 Angle Test and Temperature Measurement Timing

The angle test and the temperature readout is based on the same mechanism.

In the Normal Mode, the output path is linked to the angle test or to the temperature measurement unit until the mode is terminated.

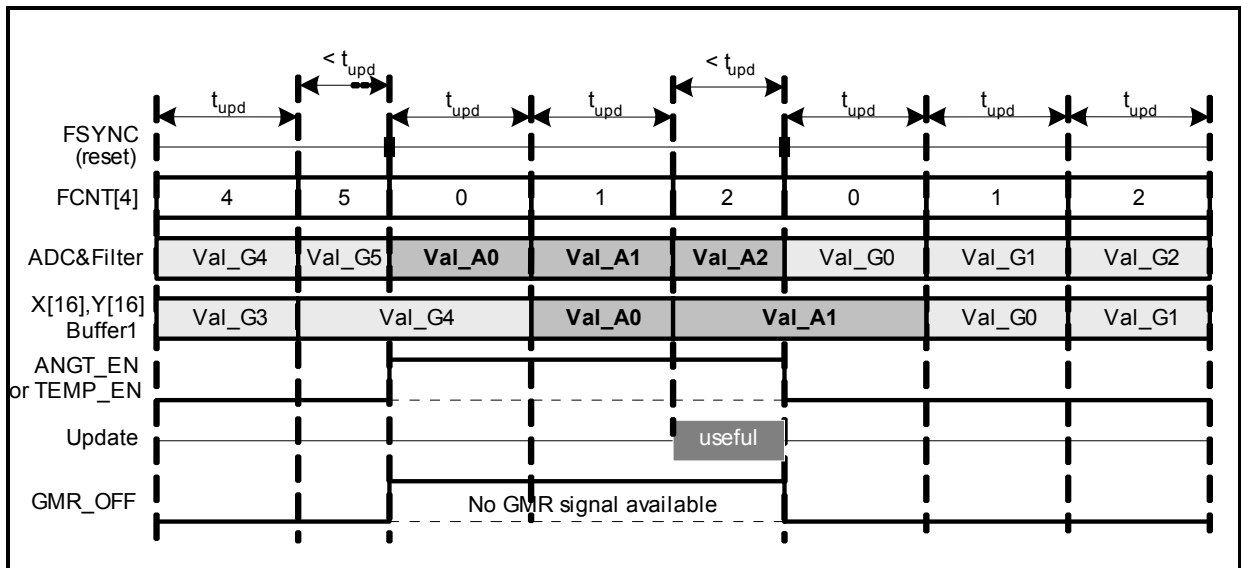

Figure 15 Measurement in Normal Mode

In Automatic Mode, the signal is automatically switched back to GMR measurement after the read-out of one value.

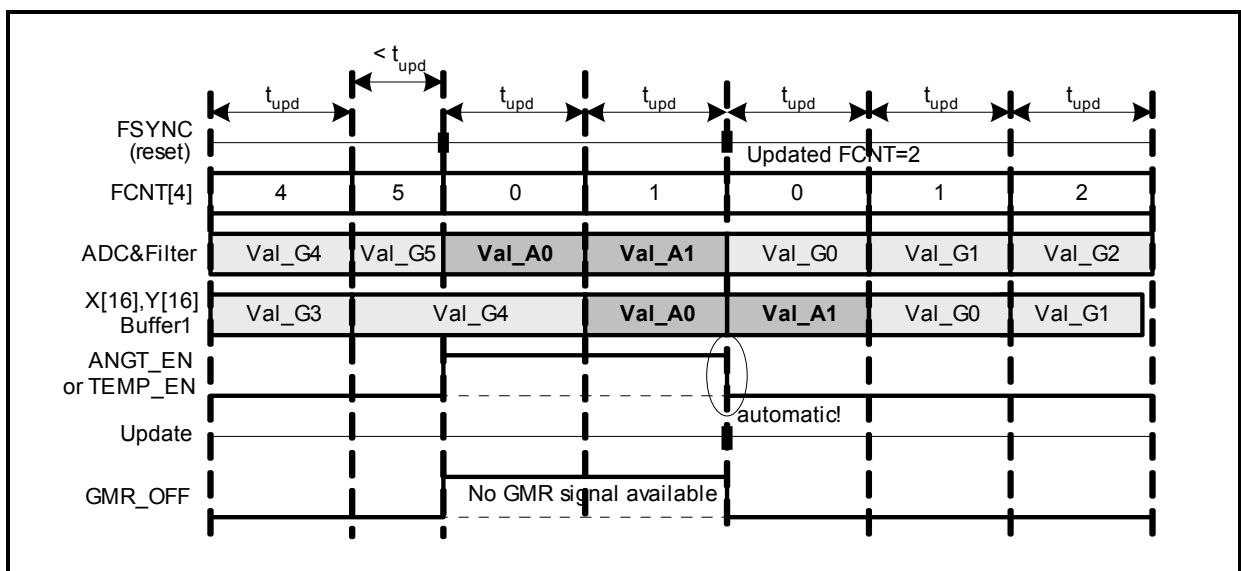

Figure 16 Measurement in Automatic Mode

## 12 Overvoltage Comparators

Various comparators monitor the voltage in order to ensure a error free operation. The overvoltages must be active for at least  $t_{DEL}$  to set the test comparator bits in the SSC Interface registers. This works as digital spike suppression.

**Table 19 Test Comparators**

| Parameter              | Symbol       | Limit Values |      |      | Unit    | Notes  |
|------------------------|--------------|--------------|------|------|---------|--|
|                        |              | min.         | typ. | max. |         |  |
| Overvoltage Detection  | $V_{OVG}$    | -            | 2.80 | -    | V       |  |
|                        | $V_{OVA}$    | -            | 2.80 | -    | V       |  |
|                        | $V_{OVD}$    | -            | 2.80 | -    | V       |  |
| $V_{DD}$ Overvoltage   | $V_{DDOV}$   | -            | 6.5  | -    | V       |  |
| GND - Off Voltage      | $V_{GNDoff}$ | -            | 0.54 | -    | V       | $V_{GNDoff} = V_{GND} - V_{TST1}$  |
| $V_{DD}$ - Off Voltage | $V_{VDDoff}$ | -            | 0.48 | -    | V       | $V_{VDDoff} = V_{CLK} - V_{DD}$<br>or $V_{SCK} - V_{DD}$                             |
| Spike filter Delay     | $t_{DEL}$    | -            | 10   | -    | $\mu s$ | The error condition has to be longer than this value (min. 256 clocks of $f_{DIG}$ ) |

### 12.1 Internal Supply Voltage Comparators

Every voltage regulator has an overvoltage comparator to detect a malfunction. If the nominal output voltage of 2.5 V is larger than  $V_{OVG}$ ,  $V_{OVA}$  and  $V_{OVD}$ , then this overvoltage comparator is activated. It sets the  $VRx\_OV$  bit.

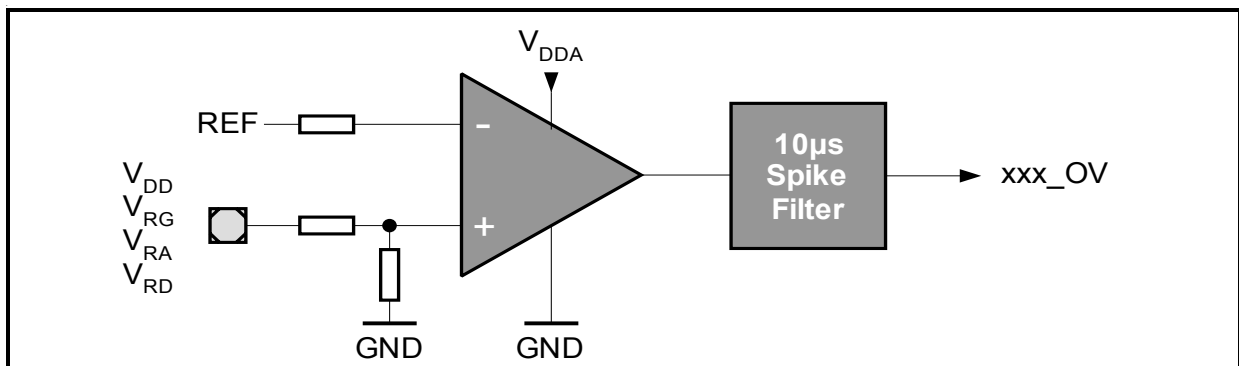

**Figure 17 OV Comparator**

### 12.2 $V_{DD}$ Overvoltage Detection

The Overvoltage Detection Comparator monitors the external supply voltage at the  $V_{DD}$  pin. It activates the  $STAT\_VR$  (see [Figure 17](#)).



### 12.3 GND - Off Comparator

The GND-Off Comparator is used to detect a voltage difference between the GND pin and TST1 (which must be soldered to GND in the application). It activates the *STAT\_VR* bit. This circuit can detect a disconnection of the Supply GND Pin.

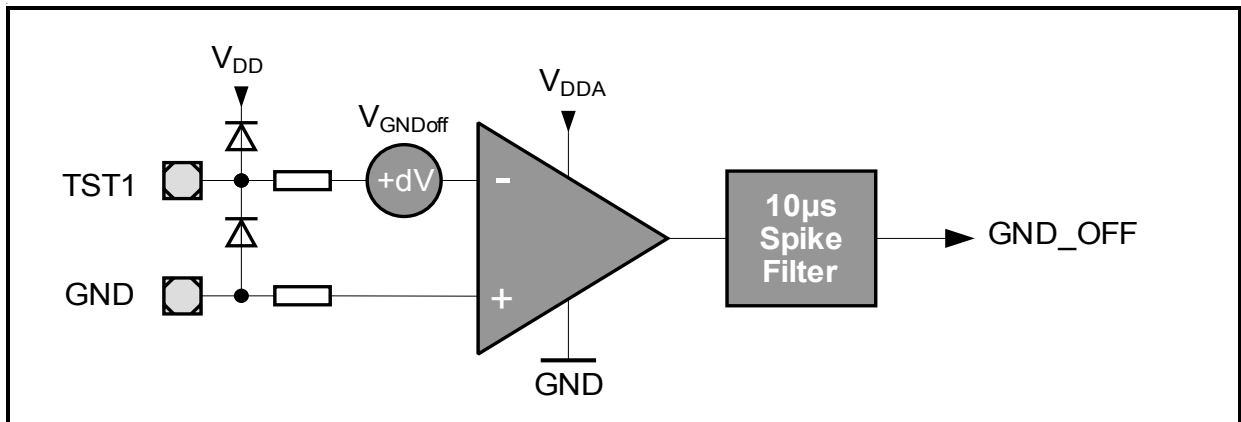

Figure 18 GND - Off Comparator

### 12.4 V<sub>DD</sub> - Off Comparator

The V<sub>DD</sub>-Off Comparator detects a disconnection of the V<sub>DD</sub> pin supply voltage. In this case, the TLE5011 is supplied by the SCK, CLK and CS input pins via the ESD structures. It activates the *STAT\_VR* bit.

The retriggerable analog monoflop is necessary because of the non-static signal of the CLK and SCK signals.

This comparator is also activated if spikes on CLK or SCK achieve the condition:

$$(V_{CLK} - V_{DD}) > V_{VDDoff} \text{ or } (V_{SCK} - V_{DD}) > V_{VDDoff}$$

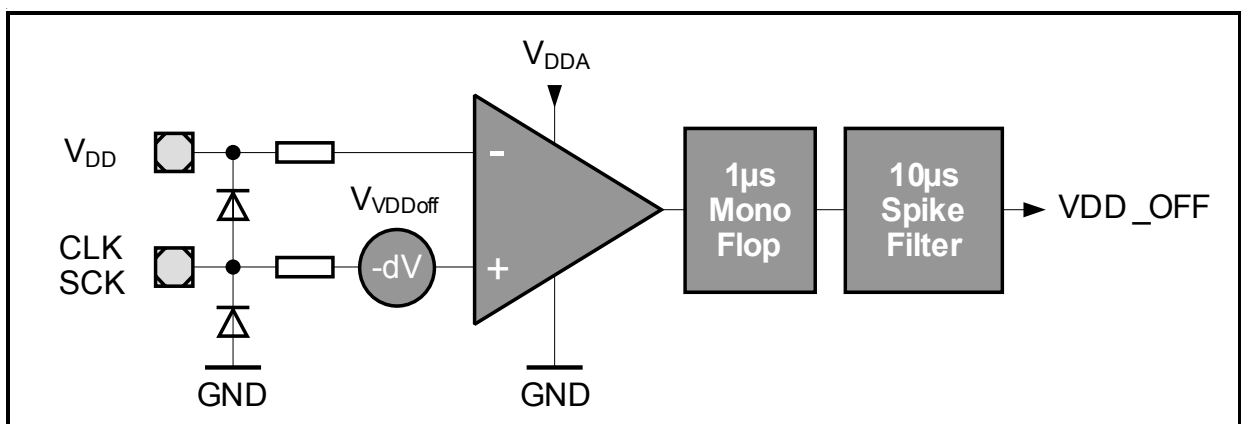

Figure 19 V<sub>DD</sub> - Off Comparator

### 13 Typical Application Circuit

The application circuit shows the microcontroller version with Open Drain capabilities.

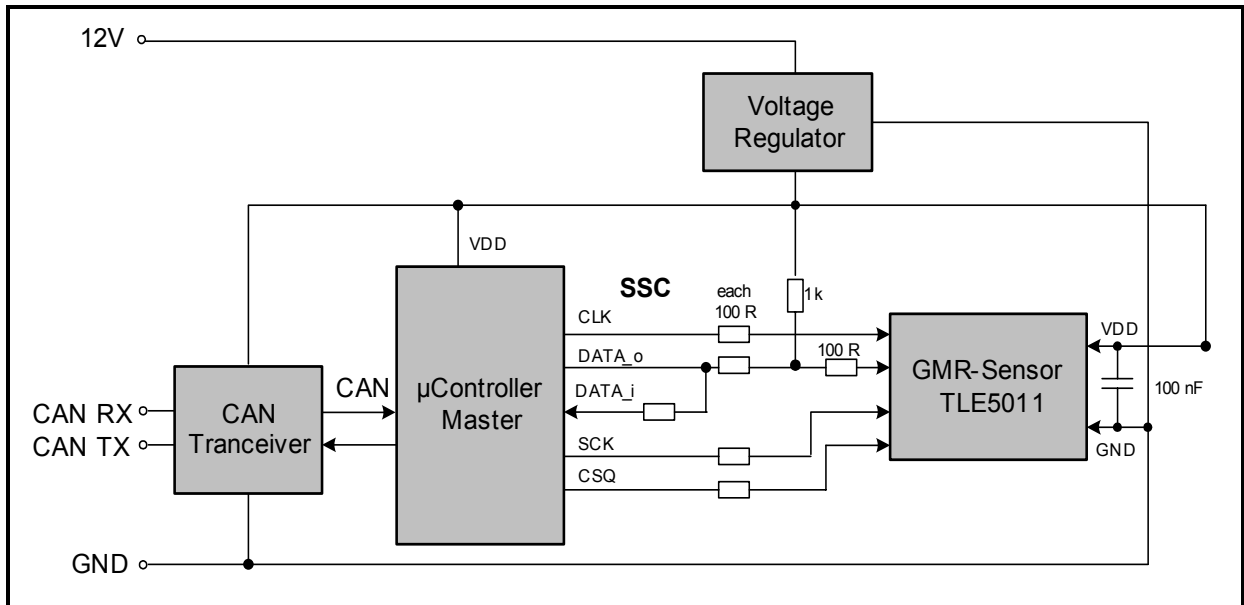

Figure 20 Application Circuit

#### 13.1 Angle Sensor System

A complete system may consist out of one TLE5011 and a microcontroller. The second TLE5011 may be used for redundancy to increase system reliability. The microcontroller should contain a CORDIC coprocessor for fast angle calculations and flash memory for the calibration data storage.

## 14 Package Information

### 14.1 Package Parameters

**Table 20 Package Parameters**

| Parameter                | Symbol     | Limit Values |      |      | Unit | Notes                         |
|--------------------------|------------|--------------|------|------|------|-------------------------------|
|                          |            | min.         | typ. | max. |      |                               |
| Thermal Resistance       | $R_{thJA}$ | -            | 150  | 200  | K/W  | Junction to Air <sup>1)</sup> |
|                          | $R_{thJC}$ | -            | -    | 75   | K/W  | Junction to Case              |
|                          | $R_{thJL}$ | -            | -    | 85   | K/W  | Junction to Lead              |
| Soldering Moisture Level | MSL 3      |              |      |      |      | 260°C                         |
| Lead frame               | Cu         |              |      |      |      |                               |
| Plating                  | Sn 100%    |              |      |      |      | > 7 μm                        |

<sup>1)</sup> According to Jedec JESD51-7

Package Outline PG-DSO-8

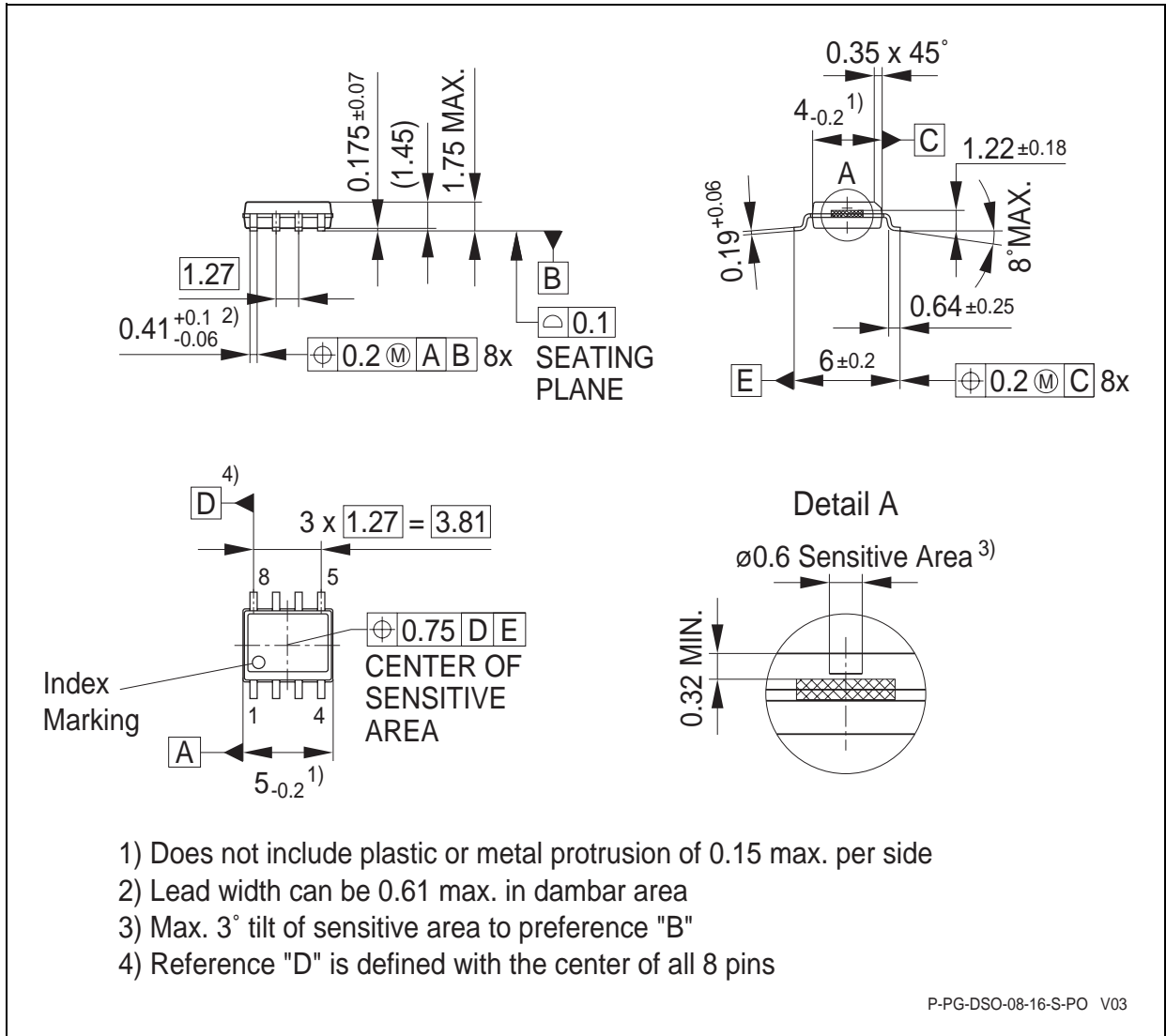

Figure 21 Package Outline PG-DSO-8

Footprint PG-DSO-8

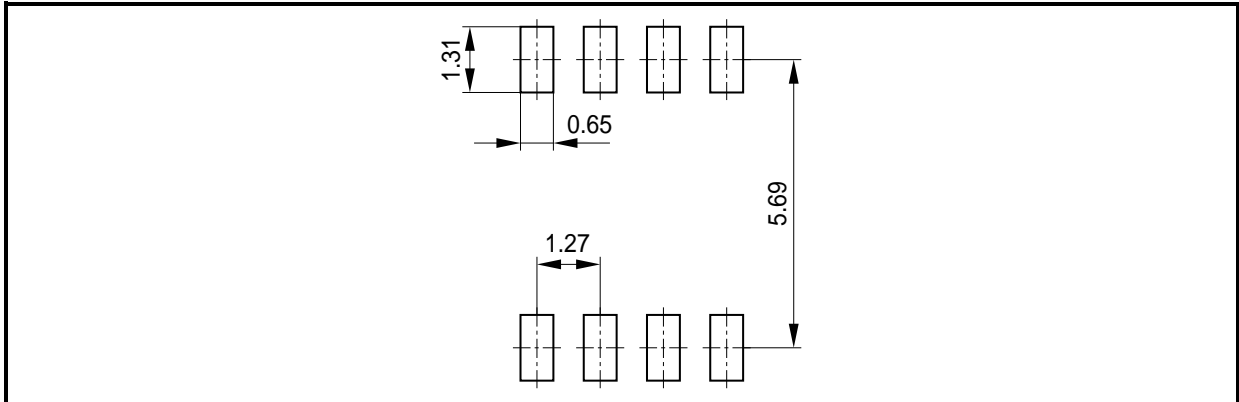

Figure 22 Footprint PG-DSO-8

Packing

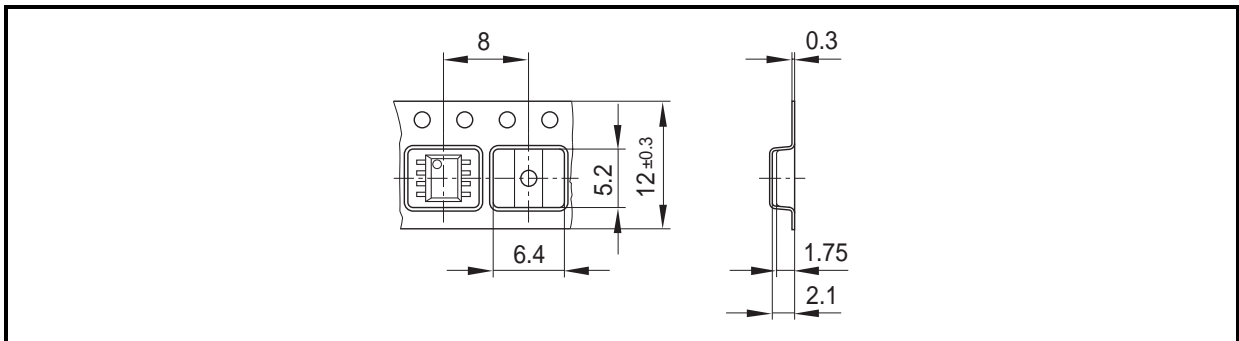

Figure 23 Tape and Reel

Marking

| Position | Marking | Description                      |
|----------|---------|----------------------------------|
| 1st Line | 5011xx  | See ordering table on page 6     |
| 2nd Line | xxx     | Lot code                         |
| 3rd Line | Gxxxx   | G .. green, 4-digit .. date code |

Processing

Note: For processing recommendations, please refer Infineon's Notes on Processing

[www.infineon.com](http://www.infineon.com)

Published by Infineon Technologies AG